

# A mathematical program for a quantum gravitation theory embedded in a hyperreal, hyperbolic 3-Lorentz manifold build on minimal surface and coercive inner geometry principles

1. A mathematical program for a unified field theory (section 0)
2. Collected information from internet/literature to related mathematical domains (section 1 ff.)

Dr. Klaus Braun  
79106 Freiburg i. Br.  
[www.quantum-gravitation.de](http://www.quantum-gravitation.de)

Work in progress document  
original version: Feb., 28, 2010

previous version: November 11, 2010  
actual version: November, 12, 2010  
changes to previous version:  
abstract, p. 25, section 15

## Abstract

*Terms: Plato vs. Archimedes, reals vs. hyper-reals, Descartes' dualism and Leibniz' monad concept, Newton's "particle" vs. Leibniz's "field" infinitesimal concepts, particle vs. analytical mechanics, Newton's momentum (impressed forces)/standard continuity vs. Leibniz' living forces (vis viva, standard vs. non-standard continuity, virtual vs. actual displacement,  $dx$  vs.  $\delta x$ , causal vs. purpose (physical) principle, Heissenberg vs. Schrodinger,  $l_1$  vs.  $L_2$  Hilbert spaces, Lagrange vs. Hamiltonian formalism, point particles vs. fields/wave, minimal surface vs. torsion-freedom, particle-field dualism, eigen differentials, non standard analysis.*

Section 0 gives the overall idea of the proposed new mathematical concept for a unified field theory, which is hyper-real in a double sense, This is about a newly proposed physical principle based on Leibniz's philosophy to be described in a non-standard number analysis to overcome this issue of (massless) particles without extentions, but with energy, i.e. overcome current particle-wave dualism paradoxon. A proper hyperbolic 3-Lorentz-manifold (required to be being consistent with Huygens' principle), not building on metrization and torsion-free conditions for co-variant differentials, but on metrization and minimal surface conditions (the later one is built on variation argument in direction of the normal) defining attributes might enable a consistent k-form framework for a variational framework to model gravitation PDE. As a side effect this hyperbolic framework might generate specific spherical non-standard waves, replacing current wave models in quantum or gravitation theory.

Based on the proposition that hyper-real number are more appropriate to model the "real" mathematical entities than the real numbers, enabling an appropriate model physical forces in the sense of Leibniz, it's suggested to start first with a look at Leibniz formula

$$d(xy) = xdy + ydx + dxdy = xdy + ydx$$

In standard analysis the term  $dxdy$  is neglected as infinitely small of second order. In a hyper-real context (in combination with k-form theory) the equivalence of the Lagrange and Hamiltonian formalism (variation in the direction of the curve), reflecting the physical principles of causality and purpose, might no longer be valid in the purely hyper-real world, where an adequate action principle makes only sense based on "purpose principle", not based on "causality-principle". This might leverage an appropriate (purely Hamiltonian formalism) model beyond the Heissenberg uncertainty border. The Legendre transformation

$$g := g(x, y) := \psi y - f = y\psi(x, y) - f(x, y)$$

enables the equivalence between both formalism. In a hyper-real world this might lead to an alternative expression in the form

$$d(g) = (y + dy)d\psi - \frac{\partial f}{\partial x} dx \quad .$$

In the light of this e.g. the concept of affine connexions in current tensor theory framework might get some modifications.

## 0. A mathematical program for a unified field theory

### In a nutshell

Currently there are two one-way roads ending up in quantum theory and gravitation theory. Both together are inconsistent, i.e. there must have been a branch somewhere back the road, where underlying common sense assumptions lead to two different ways forward.

From Michio Kaku, Introduction to Superstrings and M-Theory, Springer Verlag, New York (1.2) we recall:

*Because general relativity and quantum mechanics can be derived from a small set of postulates, one or more of these postulates must be wrong. The key must be to drop one or more of these assumptions about Nature on which we have constructed general relativity and quantum mechanics. Over the years several proposals have been made to drop some of our commonsense notions about the universe: continuity, causality, unitarity, locality, point particles.*

We will focuss on the later commonsense notation, which is about "point particle" and move back to Newton and Leibniz where the branch seems to be. Before that we recall from Abraham Robinson (Non-standard Analysis, Amsterdam: North-Holland, 1966):

*"... it appears to us today that the infinitely small and infinitely large numbers of a non-standard model of Analysis are neither more nor less real than, for example, the standard irrational numbers."*

Today we think of the set of real numbers as equivalent to the set of points of the real line - a sort of ruler extending endlessly in both directions from the point corresponding to zero. To the ancient Greeks, there were only points corresponding to rational numbers (ratios of whole numbers, e.g.,  $2/5$ ) and between any two points on a line there were only a finite number of such rational "points". When irrational numbers were discovered, they were deemed "incommensurable", meaning they could not be expressed as such ratios and, in a sense, were non-measurable.

From a mathematical point of view the difference between the field of hyper-real and real numbers is the missing *Archimedian principle*, which is, that the set of natural numbers is not bounded by a real number. This (missing commonsense assumption) might already indicate an appropriate modification of Heisenberg/von Neumann quantum mechanics Hilbert space framework, just by replacing the summation indices out of  $\mathbb{N}$  by indices out of  $\mathbb{N}^*$ .

As mathematical sophistication increased since Leibniz, the ideas of Cauchy, Weierstrass and others took hold, and monads and moments - in their original guise - faded away. In the Standard Analysis that derived from their work, all real numbers were either rational or irrational, and "infinitesimal" came to mean simply very, very small, but real.

There is an effective limit to the measurability of distances between points that are extremely close together. So, in a sense, there are "spaces" around points in which infinitesimals might reside. Perhaps aspects of logic break down, as they seem to in quantum mechanics, when dealing with microcosmic worlds.

Leibniz's differential calculus, which enabled the mathematical modelling of continuity and continuous functions in combination with Newton's massless particle model in the context of his mechanics models (also to describe gravitation) got a great success. At the very end this approach in combination with Einstein's gravitation theory lead to massless particle, which are purely energy, but still acting as particle, which can only be influenced by independent acting forces on it. On the other side, forces are only measured in such a way, that massless particles are assumed and observed due its behaviour to such forces. In other words: the forces are transcendental, and the massless particles are "real". Applying continuity is in such a framework at the very end not possible, which is in line with Heissenberg's uncertainty relation.

Why not turning the whole thing around, gonig back to the complete idea of Leibniz, which lead him to his differential calculus?

Leinbiz proposed monads, which are completely independent with its own "internal" living force. The relations between monads are somehow "self-organizing" via a proposed "pre-defined harmony" concept. In modern terminology this could mean, that the first one describes a real continuity beyong our world, where the border is given by Heissenberg's uncertainty relation (which is valid in the Hilbert-space  $L_2 \cong l_2$ ). The later one proposes instead of "causality" a "purpose", which is responsible for an appropriate "inter-relation" of the living forces (=monads). The definition of non-standard numbers ([Ro]) is very much related to Leibniz's monad concept. It is based on infinite series of numbers with certain properties. Trying to make a link already from this to  $l_2$  might indicate relations of non-standard (hyper-real) numbers to quantum theory "particle" modelling.

Another relation to some basic concepts of standard quantum mechanics might be, roughly speaking, moving from a discrete eigenvalues producing bounded, hermitian and positive definite operator to a bounded, hermitian operator only. The Leibniz concept of the monad is per definition transcendental, i.e. additionally, if one would accept a living force as physical "reality" a continuous eigenvalue spectrum becomes physical relevant (from a non empirical perspective), i.e. the spectral theorem (developed by Hilbert, von Neumann, Dirac) can be applied to (see also §18). This would put an alternative light for instance on modelling the zero point energy.

The framework of the super-gravitation theory is a (4+n)-dimensional space. A unification model of the three elementary forces  $SU(3), SU(2), U(1)$  are proposed to be by e.g.  $SU(5)$  (which can be interpreted also as Kaluza-Klein theory or  $O(10)$  or  $E(6)$ ) replacing the combined  $SU(3) \otimes SU(2) \otimes U(1)$  symmetry group. This “GUT trial” requires 24 Yang-Mills fields.

The framework of the super-string theory is an 11 dimensional space. Its key concept is modelling the different particles as real extension (with some distance) of virtual points to a string, having different possible vibration modi (which is basically the same, than proposing different energy levels) to differentiate different possible particle types.

Both approaches do not allow a consistent match to the graviton. Both approaches already use implicitly transcendental objects, which are the mathematical points, either as necessary concept of the underlying mathematical model (which is being seen as proof of concept for the physical concept itself) or as necessary, imaginary point in a physical field, just refer to, in order to describe the action of a transcendental force of a field.

Instead of this, following Leibniz, why not proposing that there is only one “true” entity (instead of *photons, gluons, leptons,  $W^+, W^-, Z^0$  bosons, gravitons.*), which combines both attributes, “particle” and “living force (vis viva)” “within” one substance, which is the **monad** of Leibniz.

G.W. Leibniz, *Monadologie*, Philipp Reclam Jun., Stuttgart.

From [Fi] Fischer K. we recall a few statements:

*A substance (=monad=points de substance; monas, i.e gr. “entity”, “unique entity”, “Einheit”, “das Eine”) is a meta-physical point (points de métaphysiques).*

*A physical point requires “extension” to explain mechanics (which is related to the mathematical concept of a metric); a mathematical point has no extension, but its real existence is missing (which is related the mathematical concept of a field). The monad fulfills both requirements. The force has to be seen as substance and the substance can only be thought as force. The force is transcendent, i.e. can not be observed and measured; only the action of force is an observable variable. In a pure world of bodies everything is mechanically. Force is therefore a term, which goes beyond this word (fons mechanismi).*

This concept has to be emdedded in the existing (gravitation) field concept, which is based on Einstein’s space-time struce, i.e. a 4 dimensional oriented and time-like oriented Lorentz manifold with a twofold, covariant  $C^\infty$  – tensor field  $g$ . For every time-like vector  $x$  of such a Lorentz space (i.e. for every vector  $x$  of the space-time structure, which fulfils  $g(x, x) > 0$ ) the sub-space

$$x^\perp := \{y \in E : g(x, y) = 0\} ,$$

equipped with the metric  $-g$ , is euclidical. For two future-oriented vectors  $x$  and  $y$  of a Lorentz space with  $g(x, x) = g(y, y) = 1$  it holds  $g(x, y) \geq 1$

## Two types of “standard” forces

1. There are forces which maintain the given kinematical conditions:

Let  $W$  denote the work,  $d\vec{s} = \vec{v}dt$  and the momentum (impulse)  $\vec{p} = m\vec{v}$ . The work of forces to a body is the same as the increase of body's kinetic energy:

$$dW = \vec{F}d\vec{s} = (\vec{F}d\vec{v})dt = ((m\dot{\vec{v}})d\vec{v})dt = d\left(\frac{m}{2}\vec{v}^2\right) = (m\vec{v})d\vec{v} = \vec{p}d\vec{v} =: dT$$

resp. 
$$W = \int_{t_1}^{t_2} \vec{F}d\vec{s} = \frac{m}{2}(\vec{v}_2^2 - \vec{v}_1^2) = T_2 - T_1$$

I.e.  $W$  gives all work, which all forces act in the time interval  $[t_1, t_2]$ .

The analytical treatment of mechanics does not require knowledge of these forces.

The total differential of the action as function of the coordinates and the time is a 1-form

$$\omega = dS = \sum p_i dq^i - Hdt .$$

Its differential

$$d\omega = \sum dp_i dq^i - dHdt$$

is integral invariant, which is relevant for corresponding “Erhaltungsgrößen”, leading to the Lagrange identities.

2. There are forces which come from an external field or from the mutual interaction of particles:

The quantity of prime importance for the analytical treatment of mechanics is not a force, but the work done by impressed forces for arbitrary infinitesimal displacements. They are analytically defined as the coefficients of an invariant differential form of the first order, which gives the total work of all the impressed forces for an arbitrary infinitesimal change of the position of the system.

A mathematical framework is required to bridge from Leibniz's “monad” concept to monads as physical entities (with differential forms as mathematical counterpart). With that the monads would not only solve/unite Descartes' matter-spirit issue/separation, but also the current inconsistencies between quantum and gravitation models. This would enable an unified quantum and gravitation field theory. There already exists a mathematical framework dealing with “monads”, which are the hyper-real numbers building the foundation of the non-standard analysis. Therefore the required mathematical framework is likely to be built in a hyper-real (non standard analysis) variational theory framework, being consistent with Hamiltonian principle.

“Duality” is likely to be THE guiding principle to build an adequate mathematical model,

- enabling a characterization of the 4 dimensional hyper-real Einstein space as THE valid space-time continuum with appropriate hyper-real spherical waves
- explaining the asymmetry of the time arrow in an only real 4-dim. Einstein space
- explaining physical constants and “observed” particles as observations and measurable quantities, when crossing the border from the “hyper-real” to the “real” (world) state.

A standard physical principle for the Nature for our **real** world is “**purpose**” and “**causality**”, which are both from a mathematical point of view **equivalent**. This physical principle remains valid for the **hyper-real** world concerning “**purpose**”, while “causality” is out of scope of any measurable experience and observation capability, which is beyond the velocity of light (*the latest experimental results about “superluminal barrier traversal” are explained and modelled by “virtual” photon on top of “real” photons* (!!!)).

The variational theory is likely also to be the appropriate framework for scattering and variance modelling.

### The harmonic (quantum) oscillator and the Hilbert transform

In the one-dimensional case the concept of hyperfunctions enables a link between distributions and a holomorphic, i.e. a complex-analytical function, as any distribution  $f$  on  $\mathbb{R}$  can be realized as the “jump” of the corresponding in  $\mathbb{C} - \mathbb{R}$  holomorphic Cauchy integral function

$$\hat{f}(x) := F(x) := \frac{1}{2\pi i} \oint \frac{f(t)dt}{t-x}$$

across the real axis, given by

$$(f, \varphi) = \lim_{y \rightarrow 0^+} \int_{-\infty}^{\infty} (F(x+iy) - F(x-iy))\varphi(x)dx \quad \text{for } y \rightarrow 0^+ .$$

A real function and its Hilbert transform together create a so called strong analytical signal. This signal can be written with an amplitude and a phase where the derivative of the phase can be identified as the instantaneous frequency. A function and its Hilbert transform are orthogonal. A function and its Hilbert transform have the same energy and therefore the energy can be used to measure the calculation accuracy of the approximated Hilbert transform. The Hilbert transform defined in the time domain is a convolution between the Hilbert transformer  $\frac{1}{\pi t}$  and a function  $f(t)$  .

The simplest version of the harmonic oscillator is the Hamiltonian system with Hamiltonian

$$H(p, q) = \frac{1}{2}(p^2 + \omega^2 q^2) \quad \text{and} \quad \dot{q} = p, \quad \dot{p} = -\omega q, \quad \ddot{q} = -\omega^2 q$$

Identifying  $R^2 \cong C$  by putting  $z = p + i\omega q$  a solution to  $H(p, q) = \frac{1}{2}|z|^2$  is given in the form

$$z(t) = Ce^{i\omega t} .$$

The Hermite polynomials are used to model the energy states of the harmonic quantum oscillator. A complex function is called Hermitian if its real part is even and its imaginary part is odd. If  $g(t)$  is a real function, then e.g.  $\hat{g}(\xi)$  is Hermitian and therefore  $|\hat{g}(\xi)|^2$  is even. A complex signal  $u$  is called a strong analytical signal if it holds  $Hu = iu$ . For strong analytical signals  $u$  it holds  $H(\text{Re}(u)) = \text{Im}(u(x))$ , i.e.

$$z(t) = u(t) + iH(u(t))$$

is a strong analytical signal. From this, the combination of Hermite polynomials with its Hilbert transforms in the form

$$z_n(t) = \varphi_n(t) + i\widehat{\varphi}_n(t) ,$$

define an alternative orthogonal system for the solution space of the harmonic quantum oscillator. This might provide an alternative model for the zero point energy of the harmonic quantum oscillator, which might overcome current inconsistencies between the Casimir effect (i.e. existing radiation at absolute zero point of the temperature) and the calculated infinite energy density from the harmonic quantum operator model. The orthogonal system  $z_n(t)$  can be calculated by the following recursion formulas:

using the abbreviation

$$a_n := \sqrt{\frac{2(n-1)!}{n!}} \quad b_n := \sqrt{\frac{(n-2)!}{n!}}$$

the weighted Hermite polynomials (see section 9)

$$\varphi_n(x) := \frac{e^{-\frac{x^2}{2}} H_n(x)}{\sqrt{2^n n! \sqrt{\pi}}} \quad \text{with} \quad H_n(x) := (-1)^n e^{x^2} \frac{d^n}{dx^n} e^{-x^2} , \quad H_0(x) = 1, \quad H_1(x) = x ,$$

fulfill the recursion formula

$$\varphi_n(x) := a_n x \varphi_{n-1}(x) - (n-1) b_n \varphi_{n-2}(x) , \quad \varphi_0(x) := \pi^{-1/4} e^{-\frac{x^2}{2}} , \quad \varphi_1(x) := 2^{-1/2} \pi^{-1/4} x e^{-\frac{x^2}{2}} .$$

The corresponding recursion formula for the Hilbert transforms of the Hermite polynomials is given by

$$\widehat{\varphi}_n(x) := a_n \left[ x \widehat{\varphi}_{n-1}(x) - \frac{1}{\pi} \int_{-\infty}^{\infty} \varphi_{n-1}(y) dy \right] - (n-1) b_n \widehat{\varphi}_{n-2}(x)$$

$$\hat{\varphi}_0(x) = \pi^{1/4} \int_{-\infty}^{\infty} e^{-\frac{\omega^2}{2}} \sin(\omega x) d\omega \cdot$$

In any relativistic theory the vacuum, the state of lowest energy, if it exists in „reality“ (with its ir-rational numbers as model for physical points), has to have the energy zero (or has to have an infinitely small energy in a hyper-real world!!?!).



## Introduction

Both, gravitation theory and quantum theory provide an accurate model to describe “reality” within their own domain. The theories become inconsistent, when linking them together, i.e. a quantum gravitation theory, which unites both, is missing. In a journalistic way the current unsolved answers and inconsistencies got the branding “particle-wave dualism”. From a philosophical point of view this is very much in line with Descartes’ philosophy.

The key to solve current inconsistencies must be to drop or change one or more of the commonsense assumptions about Nature (see [Ka] Kaku M., 1.2) i.e. continuity, *causality*, unitarity, locality, point particles, based on which both theories have been constructed.

From a philosophical perspective ([Fi] Fischer K.) the “particle-wave” “duality” is related to the contradictory concepts of Plato (“ideal” world) and Aristoteles (“empirical” world). The later one provides our today’s state of the art to see and define science. Descartes accepted both “worlds”, but strictly separated between matter and spirit as two different “worlds” without any interacting relations.

Leibniz united and solved Descartes’ “splitted matter and spirit world” into one consistent philosophical model, building on the concept of “monads” ([Fi] Fischer K.). The monads lead also to the “birth” of the mathematical calculus concept, in parallel to Leibniz driven from a physicist’s perspective by Newton leading to the great concept of classical mechanics. The success of the classical mechanics model, built on the concept of an existing “infinitesimal distance”, resulted into a widely acceptance of “real number” as “real” numbers, even those include irrational numbers and an only small part are rational numbers. In combination with the mathematical concept of a “function” related this enabled the definition of terms like “speed” and “momentum”, which lead the mathematical concept of “**continuity**”.

To describe classical mechanics there are the two great (mathematically equivalent) formalisms: it’s the Lagrange (particle mechanics) and Hamiltonian (energy; analytical mechanics) formalism. Both formalisms are from a mathematical point of view “least action principles” or “variational principles” to model (continuous!) motions of particles.

The key observation and “property” of the Hamiltonian formalism is, that the underlying “philosophical” principle of the “least action principle” is not about **causality**, but about “**purpose**”, i.e. minimizing action along an infinitesimal small distance.

The “ $dx$ ”-concept of differential calculus is only part of Leibniz’s solution of Descartes’ dualism concept. His “full” solution model, the “monad” concept, got in the meantime a mathematical description ([Ro] A. Robinson et. al), which is the non standard analysis, based on non-standard numbers (hyper-reals), which includes the real numbers. The concept of continuity (as most of all other standard mathematical concepts and theories) keeps being valid in that sense, that the restriction to only real numbers gives the “standard” continuity.

Our proposal to solve current particle-wave dualism in a hyperbolic Maxwell and Einstein world is the following:

to apply Leibniz's concept completely and consistently to the Hamiltonian formalism, based on an appropriate extension from "real" to "hyper real" world and based on a new physical principle, which is in line with the key proposition of Leibniz's philosophy:

**1. to extent "particle"/"continuity" to the (trancendent) "hyper real" case**

Replace real number by "hyper real" number to model a "particle", still without any physical extension. As a consequence the definition (!) of "continuity in a standard sense" (which is to the author's opinion not a philosophical principle, but only a term resp. definition) has to be replaced by "continuity in a non-standard sense".

**2. only assume "purpose", not "causality" for the (trancendent) "hyper real" case**

modelled by hyperbolic PDE using variational principles (with its underlying concepts of actual and virtual displacements), i.e. "least action principle".

This concept proposes

### **A. a new (explicit transcendental) physical principle ...**

There is only one force in a 4 dimensional (non-standard) space-time continuum, which unites the known existing 4 forces in the nature. The underlying source, which is at the same time the “basic” entity=quantum=inflaton is the “monad”, which has its “own” force (Leibniz’ “vis viva”, which is a transcendental form). The measurable and realized force in our “real” world is a radiation out of the “monad”, mathematically described as a specific spherical wave as solution of a hyperbolic radiation equation in a non-standard analysis framework. All, what’s within the monade, i.e. beyond the border from “real” to “hyper-real”, is “transcendent” in the sense of Kant, but there is still a principle of “purpose” valid, which guarantees the linkage to our world’s causality; as this “purpose” get its realization on this side of the border, both is valid, the same purpose, which now is equivalent to causality, i.e. Lagrange formalism becomes valid, too.

### **B. ... a mathematical program for a consistent model combining quantum (particle) and gravitation (field) theory**

which necessarily has to unite Maxwell and Einstein equation consistently, overcoming current inconsistencies about necessary singular behavior of electronic particle, solving a hyperbolic (radiation) differential equation described by “least action principles” (as Einstein’s gravitation equations) in a non-standard analysis framework, modelling a radiation acting out of “monades”, which fits to Maxwell’s and Einstein’s equations. In case this would be successful there then will be a direct link from Maxwell’s electron ( $U(1)$ ) (in 4 dimension time-space continuum) to Einstein’s graviton (in a 4 dimensional Einstein space), without having to go via  $SU(2) \otimes U(1)$  and potential  $SU(2) \otimes O(10)$  models, in which case for each step the number of dimensions has to be increased to ensure consistency until eleven, at least. *The field of real numbers  $R$  can be interpreted as the Lie algebra of the compact, one-dimensional group  $U(1)$ , in which the only relevant attribute of an electron within the Maxwell theory – i.e. the electric charge - is modelled. For more complex particles, which requires additional defining attributes (e.g. color, taste), the “standard modelling approach” requires a higher dimensional Lie group (a Lie group is a group, which is at the same time a manifold to allow differential calculus, Lie derivatives are tensor fields which keep invariant under symmetry operations).*

## The divergence

The concept of divergence is especially important in those areas concerned with the behavior of vector fields. The divergence of the energy-stress tensor is zero, which plays a key role, when defining Einstein's gravitation equation. The divergence theorem (the flux of a vector field through a closed surface  $S$  is equal to the integral of the divergence of that field over a volume  $V$  for which  $S$  is a boundary) plays a key role within the Maxwell equations.

Positive divergence is associated with the "flow" of electric field lines away from positive charges. Flux is defined over an area, while divergence applies to individual points. In case of a fluid, the divergence at any point is a measure of the tendency of the flow vectors to diverge from that point; i.e. to carry out more "material" away from it than is brought towards to it. Those points of positive divergence are sources, while points of negative divergence are sinks.

In case of a point charge at the origin, the flux through an infinitesimally small surface is nonzero only if that surface contains the point charge. Everything else, the flux into and out of that tiny surface must be the same, and the divergence of the electric field must be zero.

The mathematical definition of divergence may be understood by considering the flux through an infinitesimal surface surrounding the point of interest. If you were to form the ratio of the flux of a vector field  $\vec{E}$  through a surface  $S$  to the volume enclosed by that surface as the volume shrinks towards zero, one would have the divergence of  $\vec{E}$  :

$$\operatorname{div}\vec{E} = \lim_{\Delta V} \frac{1}{\Delta V} \oint_S \vec{E} \circ \vec{n} da .$$

This definition also states the relation between flux and divergence. Vector fields with zero divergence are called "solenoidal" fields.

The Maxwell equations produce the wave equation, which is the basis for the electromagnetic theory of light. A phenomena of the Maxwell equations is the **electromotive force** (emf), involving movement of a charged particle through a magnetic field, defined by

$$\operatorname{emf} := -\frac{d}{dt} \oint_S \vec{B} \circ \vec{n} da .$$

The negative right hand side plays a key role in Lenz's law, which is about the direction of the current induced by changing magnetic flux (flow always in the direction so as to oppose the change in flux).

The flux ("number of field lines") of a vector field  $\vec{E}$ , which represents a "fluid flow/stream model to "which places" the fluid flow transports a particle along an integral curve  $\gamma$  (characterized by  $\gamma'(t) = \vec{E}(\gamma(t))$  during a certain time span  $t \in (0, a)$ ). For a point  $P = \gamma(0)$  this is mathematically described as bundle of functions

$$\Phi_t(P) = \gamma(t) .$$

In differential geometry, the Ricci flow is an intrinsic geometric flow—a process which deforms the metric of a Riemannian manifold—in this case in a manner formally analogous to the diffusion of heat, thereby smoothing out irregularities in the metric. It plays an important role in the proof of the Poincaré conjecture.

Given a Riemannian manifold with metric tensor  $g_{ij}$ , the Riemann curvature (3,1) tensor can be expressed in terms of the second derivatives of the metric; in local geodesic normal coordinate system at a given point, the components of the Riemann tensor are given by

$$R_{ikj}^k = -\frac{1}{2}(\partial_i \partial_k g_{jl} + \partial_j \partial_l g_{ik} - \partial_j \partial_k g_{il} - \partial_i \partial_l g_{jk})$$

The Ricci (curvature) tensor in local coordinates is given by

$$Ric := R_{ij} = \sum_k R_{ikj}^k,$$

so that Ricci is a trace of the Riemann tensor, i.e. it collects averages of sectional curvatures into a kind of "trace" of the Riemann curvature tensor. It is a symmetric bilinear form, as it is the metric. Beside multiples of the metric itself, it is the only such form depending on at most the second derivatives of the metric, and invariant under coordinate changes, i.e. a (2,0) tensor formed from the metric.

If we consider the metric tensor (and the associated Ricci tensor) to be functions of a variable which is usually called "time" (but which may have nothing to do with any physical time), then the **Ricci flow**  $g(t)$  may be defined by the geometric evolution equation

$$\frac{d}{dt} g(t) = -2Ric_{g(t)}.$$

In suitable local coordinate system, this equation has a very natural form. Thus, at the "time"  $t$ , choose local harmonic coordinates so that the coordinate functions are locally defined harmonic functions in the metric  $g(t)$ . Then the "evolution" equation takes the form

$$\frac{d}{dt} g_{ij} = \Delta g_{ij} + Q_{ij}(g, \partial g),$$

where  $\Delta$  is the Laplace-Beltrami operator on functions with respect to the metric  $g = g(t)$  and  $Q$  is a lower-order term quadratic in  $g$  and its first-order partial derivatives. This is a non-linear heat-type equation for  $g_{ij}$  (see also section 9).

With respect to the Poincare conjecture and the Ricci flow we recall

*Grisha Perelman: the entropy formula for the Ricci flow and its geometric applications, (submitted on 11 Nov, 2002)*

**Abstract:** *We present a monotonic expression for the Ricci flow, valid in all dimensions and without curvature assumptions. It is interpreted as entropy for a certain canonical ensemble. Several geometric applications are given. In particular, (1) Ricci flow, considered on the space of riemannian metrics modulo diffeomorphism and scaling, has no nontrivial periodic orbits (that is, other than fixed points); (2) In a region, where singularity is forming in finite time, the injectivity radius is controlled by the curvature; (3) Ricci flow can not quickly turn an almost euclidean region into a very curved one, no matter what happens far away. We also verify several assertions related to Richard Hamilton's program for the proof of Thurston geometrization conjecture for closed three-manifolds, and give a sketch of an eclectic proof of this conjecture, making use of earlier results on collapsing with local lower curvature bound.*

Some key terminologies from the Ricci calculus (physical view) and the differential forms (mathematical view) might be worth to highlight by a few examples. As partial derivatives of tensors are no longer tensor and alternative differential concept is required. This leads to the somehow variable conceptional piece of the space-time structure, the concept of (affine) **connexions**, putting euclidian tangential spaces at different space-time points of the riemannian space into relation. This is mainly about finding a coordinate independent method, to analyze if and how a tensor is changing moving from one point to another.

It is possible to introduce an invariant type of differentiation on a manifold called covariant differentiation, and when this is done the manifold is said to have an affine connexions or to be affinely connected. An affine connexion can be obtained quite naturally from a semi-riemannian structure, or from other special structures such as a parallelization or as an atlas of affinely related coordinates. Sometimes it is convenient to choose an affine connexion to use as a tool. However, there is no unique affine connexion on a manifold.

Affine connections arose historically as an abstraction of the structure of a riemannian space. The name may be due to the idea that nearby tangent spaces are connected together by linear transformations, so that differences between vectors in different spaces may be formed and the limit of difference quotients taken to give derivatives. Originally the operation of covariant differentiation was conceived of as a modification of partial differentiation by adding in corrective terms to make the result invariant under change of coordinates.

The affine connexions can be introduced also axiomatically in a somewhat broader context than is done classically. This additional generality is required to make covariant derivatives of vector fields along curves sensible. A preliminary discussion of vector fields over maps follows. A vector field along a curve is the special case, in which the map is a curve.

Ricci calculus	Differential forms
$v^\mu$ contravariant vector	there is a vector field $v = \sum_1^k v^\mu \partial_\mu$
alternating (skew-symmetric) contravariant tensor $\omega^{\mu_1 \mu_2 \dots \mu_k}$ of degree k	there is a dual k-form $\sum_{\mu_1 < \mu_2 < \dots < \mu_k} \omega^{\mu_1 \mu_2 \dots \mu_k} \partial_{\mu_1} \wedge \dots \wedge \partial_{\mu_k}$
$a_\mu$ covariant vector	there is a 1-form $\omega = \sum_1^k a_\mu dx^\mu$
An alternating (i.e. skew symmetric) covariant tensor $\omega_{\mu_1 \mu_2 \dots \mu_k}$ of degree k	there is a dual k-form $\sum_{\mu_1 < \mu_2 < \dots < \mu_k} \omega_{\mu_1 \mu_2 \dots \mu_k} dx^{\mu_1} \wedge \dots \wedge dx^{\mu_k}$
A skew symmetric, twofold covariant field tensor $F_{\mu\nu}$	there is a 2-form $\sum_{\mu < \nu} F_{\mu\nu} dx^\mu \wedge dx^\nu$

Let  $\vec{V}$  be a vector fields of a manifold  $M^n$  and  $\gamma : (a,b) \rightarrow M^n$  an integral curve of  $\vec{V}$  with tangential vector  $\dot{\gamma}(t) = \vec{V}(\gamma(t))$ . Therefore there exists to every initial point  $x \in M^n$  an integral curve  $\gamma_x : (a_x, b_x) \rightarrow M^n$  with  $\gamma_x(0) = x$ . For  $\Sigma_{\vec{V}} := \{(t, x) \in RxM^n \mid a_x < t < b_x\}$

the mapping

$$\Phi : \Sigma_{\vec{V}} \rightarrow M^n$$

$$\Phi t(x) := \Phi(t, x) := \gamma_x(t)$$

Is called the flow of the vector field  $\vec{V}$ .

If  $\vec{V}$  is a  $C^\infty$  vector field, then  $\vec{V}$  operates on  $C^\infty$  scalar fields to give  $C^\infty$  scalar fields. The Lie derivation  $L_{\vec{V}}$  with respect to  $\vec{V}$  is an extension of this operation to an operator on all tensor fields which preserves type of tensor fields, i.e.  $L_{\vec{V}}$  is a tensor field of the same type as  $\vec{V}$ .

The **Lie derivation** of a differential k-form  $\omega^k$  by a related vector field is defined as follows:

$$L_{\vec{V}}(\omega^k) = \frac{d}{dt}(\Phi_t^*(\omega^k))_{t=0} = \lim_{t \rightarrow 0} \frac{\Phi_t^*(\omega^k) - \omega^k}{t} \text{ for } t \rightarrow 0 .$$

The **Lie derivation** of a k-form  $\omega^k$  can be calculated by the Cartan derivative, i.e.

$$L_{\vec{V}}(\omega^k) = i_{\vec{V}}(d\omega^k) + d(i_{\vec{V}}(\omega^k)) ,$$

whereby  $i_{\vec{V}}(\omega^k)(W_1, \dots, W_{k-1}) := \omega^k(\vec{V}, W_1, \dots, W_{k-1})$  is the inner product of  $\vec{V}$  and  $\omega^k$ .

The **divergence of a vector field**  $A \subset M^n$  vanishes if and only if its flow consists of volume conserving diffeomorphisms.



Invariant vector and tensor fields, the flow of vector fields, Lie derivative and its geometric interpretation as divergence of vector fields as its infinitesimal volume deformation of its flow require an appropriate non-standard extension in the context of Leibniz's "vis viva". Leibniz formula is already giving non trivial differential calculus in the form

$$d(x + y) = dx + dy \quad d(xy) = xdy + ydx + dxdy = xdy + ydx .$$

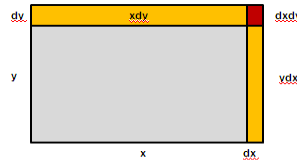

In standard analysis the term  $dxdy$  is neglected as infinitely small of second order (!). This might be a first opportunity, when extending  $k$ -forms into a non standard framework:

$$\text{Lagrange --> Hamilton: } L(x, y) \rightarrow H(x, \frac{dL}{dy})$$

The **Legendre transformation** (Lagrange --> Hamilton) of  $f(x, y)$  is defined by

$$g := g(x, y) := \psi y - f = y\psi(x, y) - f(x, y)$$

Putting  $\psi := \psi(x, y) := \frac{\partial f(x, y)}{\partial y}$  the differential of  $f(x, y)$  gives

$$df = \frac{\partial f}{\partial x} dx + \frac{\partial f}{\partial y} dy = \frac{\partial f}{\partial x} dx + \psi dy$$

As holds  $\frac{\partial [y\psi(x, y)]}{\partial \psi} = y$  and  $d(\psi y) = \frac{\partial(\psi y)}{\partial \psi} d\psi + \frac{\partial(\psi y)}{\partial y} dy = yd\psi + \psi dy$

it follows  $d(g) = d(\psi y) - df = yd\psi + \psi dy - \left[ \frac{\partial f}{\partial x} dx + \psi dy \right] = yd\psi - \frac{\partial f}{\partial x} dx + (d\psi dy) .$

The product  $d\psi dy$  is neglected to be zero in the standard theory as infinitesimal small of second order compared to  $dx$ . If one would neglected this and calculate in a non-standard way it would result into

$$d(g) = (y + dy)d\psi - \frac{\partial f}{\partial x} dx .$$

Does this change the equivalence of Lagrange and Hamilton formalism and therefore enable an appropriate model, when "moving" from the real into the hyper-real world?

## Some first steps into Maxwell and Einstein equations

Basically the mathematical program B seems to be about a non-standard tensor analysis on manifolds. A first assessment might start with the Gauss and Stokes laws (in its integral forms) to model flux out of a monad triggered by a certain energy density “within” it:

$$\oint_S \vec{E} \circ \vec{n} da = \frac{q_{enc}}{\epsilon_0} ,$$

whereby  $\epsilon_0 = 8.8541878176 * 10^{-12} \frac{C}{Vm}$  is the di-electricity constant, giving the permittivity of free space,  $q_{enc}$  the enclosed charge,  $\oint_S \vec{E} \circ \vec{n} da$  the electric flux through a closed surface S, which is the number of filed lines of the (electric) vector field  $\vec{E}$  penetrating the surface S. To include the weak forces and ending to the graviton it further needs a link to other physical constants, like the Planck’s action constant  $\hbar = 1.0545727 * 10^{-34} Js$ , the speed  $c$  of a photon and the absolute temperature  $T$ , Stefan-Boltzmann constant  $\sigma = 5.67051 * 10^{-8} \frac{W}{m^2K^4}$  which all should be realized somehow when crossing the border from hyper real into real state.

We mention the relation

$$div \vec{E} = \lim \frac{1}{\Delta V} \oint_S \vec{E} \circ \vec{n} da , \quad \Delta V \rightarrow 0 ,$$

$$curl \vec{B} = \lim \frac{1}{\Delta S} \oint_C \vec{B} \circ d\vec{s} , \quad \Delta S \rightarrow 0 ,$$

being  $\vec{B}$  a field around a closed path. The magnetic field circulation is modelled by  $\oint_C \vec{B} \circ d\vec{s}$ . Faraday’s law states that a circulating field is produced by a magnetic field that changes with time, i.e.

$$curl \vec{E} = - \frac{\partial B}{\partial t} .$$

The divergence operates on a vector field and produces a scalar result that indicates the tendency of the field to flow away from a point:

$$div \vec{E} = \frac{\partial E_x}{\partial x} + \frac{\partial E_y}{\partial y} + \frac{\partial E_z}{\partial z} .$$

The curl operates on a vector field and produces a vector result that indicates the tendency of the field to circulate around a point and the direction of the axis of greatest circulation:

$$curl \vec{E} = \left( \frac{\partial E_z}{\partial y} - \frac{\partial E_y}{\partial z} \right) \vec{i} + \left( \frac{\partial E_x}{\partial z} - \frac{\partial E_z}{\partial x} \right) \vec{j} + \left( \frac{\partial E_y}{\partial x} - \frac{\partial E_x}{\partial y} \right) \vec{k} .$$

Helmholtz's theorem says that an arbitrary vector field  $\vec{u}$  (assumed to be continuous and differentiable) can be resolved into the sum of gradient of a scalar field ("solenoidal field") and the curl of a vector field ("vortex field"). This resolution is given in the entire space:

$$(*) \quad \vec{u} = \text{grad}\phi + \text{curl}\vec{A} ,$$

where the vortex field  $\vec{A}$  can be restricted by the condition

$$\text{div}\vec{A} = 0.$$

Taking the divergence resp. the curl of (\*) one obtains

$$\nabla^2\phi = \text{div}\vec{u} \quad , \quad -\nabla^2\vec{A} = \text{curl}\vec{u} .$$

Both "Poisson's" potential equations with a given right side have a unique solution provided that  $\vec{u}$  vanishes at infinity faster than  $r^{-1}$ .

Let  $\Omega^k M$  be the vector space of differential forms of order k (k-forms), ([1] Bishop R., Goldberg S.),  $\vec{A}$  a differentiable vector field,  $M$  a boundary manifold ( $M = X \subset R^3$ ),  $f \in C^\infty(X)$  then the vector valued line-, vector valued area- and scalar volume elements are given by differential forms

$$d\vec{s} = \begin{pmatrix} dx^1 \\ dx^2 \\ dx^3 \end{pmatrix} \in \Omega^1 M \quad , \quad d\vec{a} = \begin{pmatrix} dx^2 \wedge dx^3 \\ dx^3 \wedge dx^1 \\ dx^1 \wedge dx^2 \end{pmatrix} \in \Omega^2 M \quad , \quad dV = dx^1 \wedge dx^2 \wedge dx^3 \in \Omega^3 M$$

and the following relations are fulfilled

$$df = \text{grad}f d\vec{s} \quad , \quad d(\vec{A}d\vec{s}) = \text{curl}\vec{A}d\vec{a} \quad , \quad d(\vec{A}d\vec{a}) = \text{div}\vec{A}dV .$$

The Gauss law (divergence theorem) and Stokes theorem are given by

$$\int_{M^3} \text{div}\vec{A}dV = \int_{\partial M^3} \vec{A}d\vec{a} \quad , \quad \int_{M^2} \text{curl}\vec{A}d\vec{a} = \int_{\partial M^2} \vec{A}d\vec{s} .$$

The circulation of a vector field over a closed path  $\partial M^2$  is equal to the integral of the normal component of the curl of that field over a surface  $M^2$  for which  $\partial M^2$  is a boundary.

The classical electrodynamic is modelled by the Maxwell equations

$$(1) \quad \frac{1}{c} \frac{\partial}{\partial t} \vec{E}(\vec{x}, t) - \text{curl}\vec{B}(\vec{x}, t) = -\frac{4\pi}{c} \vec{j} \quad , \quad \text{div}\vec{E}(\vec{x}, t) = 4\pi\rho$$

$$(2) \quad \frac{1}{c} \frac{\partial}{\partial t} \vec{B}(\vec{x}, t) + \text{curl}\vec{E}(\vec{x}, t) = 0 \quad , \quad \text{div}\vec{B}(\vec{x}, t) = 0 .$$

Multiplying equation (1) with  $\vec{E}$  and equation (2) with  $\vec{B}$  leads to

$$\frac{1}{c} \left[ \vec{E} \frac{\partial}{\partial t} \vec{E} + \vec{B} \frac{\partial}{\partial t} \vec{B} \right] = -\frac{4\pi}{c} \vec{j} \vec{E} - (\vec{B} \text{curl} \vec{E} - \vec{E} \text{curl} \vec{B}) .$$

The Poynting vector is defined by

$$\vec{S} := \frac{c}{4\pi} [\vec{E} \times \vec{B}] = \frac{c}{4\pi} \begin{pmatrix} E_2 B_3 - E_3 B_2 \\ E_3 B_1 - E_1 B_3 \\ E_1 B_2 - E_2 B_1 \end{pmatrix} = \frac{c}{4\pi} (|\vec{E}| |\vec{B}| \sin \theta) \vec{n} .$$

Its absolute value  $|\vec{S}|$  gives the intensity (Leistungsdichte) of a wave or the momentum density of a wave multiplied by  $c^2$ .

Using the relation

$$\text{div} [\vec{E} \times \vec{B}] = \vec{B} \text{curl} \vec{E} - \vec{E} \text{curl} \vec{B}$$

is leading to

$$\frac{\partial}{\partial t} \left[ \frac{E^2 + B^2}{8\pi} \right] = -\vec{j} \vec{E} - \text{div} \vec{S} .$$

(just as a comment: at this point the quantum mechanics integrates by time  $dt$  and/or by volume  $dV$  to model e.g. energy density or the flux through the surface of the volume, if it's not the whole space; why not doing this integrated within a 4-dim. (Riemann) manifold, building on the Poincare conjecture and its positive answer?).

Let  $\vec{\vec{F}} = (F_{ik})$  be the Faraday tensor, defined by

$$\vec{\vec{F}} = (F_{ik}) = \begin{pmatrix} 0 & E^1 & E^2 & E^3 \\ -E^1 & 0 & -B^3 & B^2 \\ -E^2 & B^3 & 0 & -B^1 \\ -E^3 & -B^2 & B^1 & 0 \end{pmatrix}$$

and its corresponding Hodge-star tensor  $*\vec{\vec{F}} = (*F_{ik})$ , which is the Maxwell tensor, given by

$$*\vec{\vec{F}} = (*F_{ik}) = \begin{pmatrix} 0 & -B^1 & -B^2 & -B^3 \\ B^1 & 0 & -E^3 & E^2 \\ B^2 & E^3 & 0 & -E^1 \\ B^3 & -E^2 & E^1 & 0 \end{pmatrix} .$$

Then for the Maxwell equations (1) and (2) the following equivalent formulations are valid:

$$(1) \Leftrightarrow d * \vec{\vec{F}} = *4\pi I \quad , \quad (2) \Leftrightarrow d \vec{\vec{F}} = 0 .$$

We note the two Poincare lemmata:

1. Poincare lemma: for each differential form  $F$  it holds  $d(dF)=0$
2. Poincare lemma: for each differential form  $F$  with  $dF=0$  for an open domain of a point  $P$  there exists a differential form  $G$  with  $dG=F$ .

From the second Maxwell equations (2) it follows the existence of a scalar potential  $\phi(\vec{x},t)$  and a vector potential  $\vec{A}(\vec{x},t)$  fulfilling

$$(*) \quad \vec{B} = \text{curl}\vec{A}(\vec{x},t) \text{ and } \vec{E} = -\text{grad}\phi(\vec{x},t) - \frac{1}{c} \frac{\partial}{\partial t} \vec{A}(\vec{x},t) .$$

The movement of particles in an electromagnetic field is described by

$$(**) \quad \frac{d\vec{p}}{dt} = -\frac{e}{c} \frac{\partial}{\partial t} \vec{A}(\vec{x},t) - e\text{grad}\phi + \frac{e}{c} [\vec{v} \text{curl}\vec{A}] .$$

A field is characterized by the action it takes to the movement of charges. But the “movement” equation” (\*\*) depends from the field forces  $\vec{E}$  and  $\vec{B}$ , i.e. fields are physically identical in case of identical vectors  $\vec{E}$  and  $\vec{B}$ . In case the potentials  $\phi(\vec{x},t)$  and  $\vec{A}(\vec{x},t)$  are given, the fields  $\vec{E}$  and  $\vec{B}$  are determined. But to a given field there are different potentials, i.e. the relations (\*) do not determine uniquely the potentials  $\phi(\vec{x},t)$  and  $\vec{A}(\vec{x},t)$  as for an arbitrary function  $f(\vec{x},t)$  the (Eich-) transforms (of second kind)

$$\phi \rightarrow \phi' = \phi + \frac{1}{c} \frac{\partial}{\partial t} f(\vec{x},t) , \quad \vec{A} \rightarrow \vec{A}' = \vec{A} - \text{grad}f(\vec{x},t)$$

keeps both fields  $\vec{E}$  and  $\vec{B}$  unchanged. This leads to the additional physical request of “Eich invariance”, i.e. in a model like the above using potentials to describe observables all projections about those observables have to be invariant under such transforms. **This degree of freedom might be used to define appropriately the monad’s vacuum density that it produces the key physical constants above.**

The Maxwell equations determine the electrical and magnetic fields  $\vec{E}$  and  $\vec{B}$  as vector-valued functions on  $R^3$  by a given distribution of an electrical charge density  $\rho$  and electrical current density  $\vec{j}$ . The underlying laws to which this electrical charge density  $\rho$  and electrical current density  $\vec{j}$  are following are unknown.

The Maxwell equations are about two distinct phenomena:

- magnetic induction, involving a changing magnetic field
- **electromotive force** (emf), involving movement of a charged particle through a magnetical field

$$emf := -\frac{d}{dt} \oint_S \vec{B} \circ \vec{n} da .$$

Changing magnetic flux through a surface induces an emf in any boundary path of that surface, and a changing magnetic field induces a circulating electrical field.

The energy density, giving the distribution of energy, is a tensor being known only outside the assumed electromagnetical “particles”. The energetic factors, which give the structure of electricity of electronical particles with given size and charge, are not known.

One standard assumption is: “Matter consists of “real” “particles””

**Based on Maxwell’s equations those particles cannot be considered as electromagnetic fields without any singularities.** Based on the assumptions of “real” particles it requires additional “energical” terms, which ensure that particles with same sort of charge keep together, although there is a “push off” action between them. Poincare assumes a sort of “negative pressure” inside those particles, which compensates push off forces. The standard models assume that this pressure cannot vanish outside of the particles, which e.g. lead to an additional “pressure” term in the stress-energy tensor (A. Einstein, Grundzüge der Relativitätstheorie, p. 106):

$$T_{ik} = g_{i\alpha} g_{k\beta} \sigma \frac{dx_\alpha}{ds} \frac{dx_\beta}{ds} - g_{ik} P .$$

The Poincare lemma transforms the Maxwell field as gauge curvature ([9] Penrose R., 19.4): If a  $r$ -form  $\alpha$  satisfy  $d\alpha = 0$ , then locally there is always an  $(r-1)$ -form  $\beta$  for which it holds  $\alpha = d\beta$ . Moreover, in a region with Euclidian topology, this local result extends to a global one.

The energy-stress tensor  $T_{ik}$  is a function of the Faraday tensor

$$\vec{F} = (F_{ik}) = \begin{pmatrix} 0 & E^1 & E^2 & E^3 \\ -E^1 & 0 & -B^3 & B^2 \\ -E^2 & B^3 & 0 & -B^1 \\ -E^3 & -B^2 & B^1 & 0 \end{pmatrix}$$

i.e.

$$T_{ik} = \frac{1}{4\pi} F_{ij} F_k^j + \frac{1}{4} g_{ik} F^{lm} .$$

The energy-stress tensor  $T_{ik}$  is divergence free. According to Einstein's gravitation theory "matter tells space how to curve, and space tells matter how to move", i.e. Einstein's gravitation tensor has to fulfill

$$G_{ik} = cT_{ik} .$$

The fact is that the energy-stress tensor is divergence free. This is not true for the Ricci tensor, which leads to Einstein's field equations for the tensor field in the form

$$G := R_{ik} - \frac{1}{2} R g_{ik} = Ricci + Weyl = -\kappa T_{ik}$$

$$\text{with } \kappa = 8\pi G c^2 \approx 1.86 * 10^{-27} \text{ cm} / \text{g} .$$

The corresponding movement equations of a particle for the curve  $x^\mu = x^\mu(t)$  are given in the form

$$\frac{d}{d\tau} \left( g_{\mu,\nu} \frac{dx^\mu}{d\tau} \right) = \frac{1}{2} \frac{\partial g_{\alpha\beta}}{\partial x^\nu} \frac{\partial x^\alpha}{\partial \tau} \frac{\partial x^\beta}{\partial \tau} .$$

This is now about

- 10 equations with 10 potentials  $\Phi_{ik}$
- a non-linear relation of the potentials, i.e. the gravitation potential is not the total of single gravitations.

This is a circular structure, i.e.  $\Phi_{ik} = f(T_{ik})$  and  $space-time-structure = f(\Phi_{ik})$ . The  $T_{ik}$  is measurable, which reflect the principle of energy-momentum conservation.

## The $n \leq 4$ condition within calculus analysis

The solutions of a system of non-standard hyperbolic partial differential equations are expected to provide “spherical” non-standard (hyper-real) waves, solving a still unproven conjecture (see [CoHi] Courant R., Hilbert D., Methoden der Mathematischen Physik, II, chapter VI, §10) that spherical waves for arbitrary time-like lines do exist only in case of space-time dimension  $n = 2$  or  $n = 4$  and only then, if the underlying differential equation is of type of the wave equation. This would **characterize the 4 dimensional space-time continuum** compared to all other dimensions. This might give arguments not too early increase the number of the space-time dimension (just to ensure model consistence between the two (SU(2),SU(3)) forces), while still struggling to integrate the last force, “explaining” the graviton by a “string” (which is nothing else than a solution of a wave equation (describing again a field!), “acting” in the very small, i.e.  $10^{-18}$  environment).

I.M. Singer, J. Thorpe (the curvature of 4-dimensional Einstein spaces, Global analysis, papers in honour of K. Kodaira, p. 355-365, Princeton Univ. Press 1969) discovered a result of A. Einstein related to especially **duality of 4 dimensional manifolds**:

Let  $(M, g)$  a 4 dimensional oriented Riemann manifold,  $*$  the self adjoint Hodge operator and  $R$  the (self adjoint) Riemann curvature tensor, then it holds

$$(M, g) \text{ is an Einstein space} \quad \Leftrightarrow \quad * \circ R = R \circ * \quad .$$

## The $n \leq 4$ condition within algebra

Just searching for other mathematical areas, where  $n \leq 4$  and  $n > 4$  give some characterisation, leads to the Galois theory. It provides a connection between field theory and group theory. Using Galois theory, certain problems in field theory can be reduced to group theory, which is in some sense simpler and better understood.

Originally Galois used permutation groups to describe how the various roots of a given polynomial equation are related to each other. The modern approach to Galois theory, developed by R. Dedekind, L. Kronecker and Emil Artin, among others, involves studying automorphisms and field extensions.

Emil Artin, (1998). *Galois Theory*. Dover Publications. ISBN 0-486-62342-4 (Reprinting of second revised edition of 1944, The University of Notre Dame Press, Indiana, USA, 1948); *Galois Theorie*, Verlag Harri Deutsch, Thun, Frankfurt a.M., 1988.

If we are given a polynomial, it may happen that some of the roots of the polynomial are connected by various algebraic equations. For example, it may turn out that for two of the roots, say  $A$  and  $B$ , the equation  $A^2 + 5B^3 = 7$  holds. The central idea of Galois theory is to consider permutations (or rearrangements) of the roots having the property that *any* algebraic equation satisfied by the roots is *still satisfied* after the roots have been permuted. An important proviso is that one restricts to algebraic equations whose coefficients are rational numbers.

These permutations together form a permutation group  $S_n$ , also called the Galois group of the polynomial (over the rational numbers).



The notion of a solvable group in group theory allows one to determine whether a polynomial is solvable in the radicals, depending on whether its Galois group has the property of solvability. One starts with a field extension  $L/K$  (read: L over K), and examines the group of field automorphisms of  $L/K$  (these are mappings  $\alpha: L \rightarrow L$  with  $\alpha(x) = x$  for all  $x$  in  $K$ ). The coefficients of the polynomial in question should be chosen from the base field  $K$ . The top field  $L$  should be the field obtained by adjoining the roots of the polynomial in question to the base field. Any permutation of the roots which respects algebraic equations as described above gives rise to an automorphism of  $L/K$ , and vice versa.

In essence, each field extension  $L/K$  corresponds to a factor group in a composition series of the Galois group. If a factor group in the composition series is cyclic of order  $n$ , then if the corresponding field extension is an extension of a field containing a primitive root of unity, then it is a radical extension, and the elements of  $L$  can then be expressed using the  $n$ th root of some element of  $K$ .

If all the factor groups in its composition series are cyclic, the Galois group is called solvable, and all of the elements of the corresponding field can be found by repeatedly taking roots, products, and sums of elements from the base field (usually  $\mathbb{Q}$ ).

One of the great triumphs of Galois Theory was the proof that for every  $n > 4$ , there exist polynomials of degree  $n$  which are not solvable by radicals. This is due to the fact that for  $n > 4$  the symmetric group  $S_n$ , which is the corresponding Galois group

$$S_n = G = \text{Aut}\{K(x_1, x_2, \dots, x_n) | K\}$$

containing a simple, non-cyclic, normal subgroup, which is basically defined by an arbitrary three-cycle permutation:

$$. a \rightarrow b \rightarrow c \rightarrow a .$$

The underlying theorem, from which Abel's impossibility theorem follows, is

**Theorem:** *If  $G$  is a subgroup of the symmetric group  $S_n$  for  $n > 4$  containing all three-cycles, that is, all cyclic permutations of the form  $a \rightarrow b \rightarrow c \rightarrow a$  of three distinct elements  $a, b, c$  and if  $N$  is a normal subgroup of  $G$  with commutative quotient group  $G/N$ , then this normal subgroup also contains all the three-cycles.*

On the basis of the theorem above it now can be deduced step by step that every group in an ascending chain corresponding to a solution of the symmetric group  $S_n$  must contain all three-cycles. The chain can therefore not end up in the trivial group containing a single element, and so the symmetric group cannot be solvable.

Finally we note that a  $n$ -dimension Riemannian manifold can be embedded locally into a  $N$ -dimensional Euclidean space, if

$$N \geq \frac{n(n+1)}{2}$$

If a proper  $n$ -dimensional manifold has to be embedded into a  $2n$ -Euclidean Lagrange/Hamiltonian (particle-momentum) framework this leads to the condition  $n = 3$ .

## Some general comments

In the context of an appropriate vector and tensor analysis for monads the eigen differentials and wave packages, which are key concepts in quantum theory, would become new physical interpretations.

The new concept above would be consistent with Huygens' principles, putting another physical interpretation about the pointwise radiation along front lines and the model of shock waves, providing alternative interpretations of observed diffraction and scattering behaviors.

The new physical principles might overcome current inconsistencies between observations and quantum field theory projections giving the following explanations:

The zero point energy is proposed to be the radiation out of the "monad", which is the smallest entity, without any extension and relation to other monads (but "more" than an ideal/real point or a string). Using the word "quantum" for such a "monad" the energy density of such a quantum is called in other context as "quantum vacuum". It contains all information and all patterns of dynamic energies of the universe.

The Casimir effect shows a zero point radiation. As a request to an appropriate mathematical model the total energy of such a quantum vacuum should not be divergent.

A photon does not realize any time; how it can act in such a case? As a request to the appropriate mathematical model the asymmetry of "time" in a non-standard hyperbolic world should come out of the specific non-standard spherical "radiation" wave out of the monad.

Hamiltonian principle is linked to skew symmetric bilinear forms. In case such bilinear forms are of maximal rank it's called as symplectic form.

Für die vergangene Singularität, den Urknall, muss in etwa die Bedingung WEYL = 0 gelten, für die zukünftigen Singularitäten, schwarze Löcher, grosses Zermalmen, muss WEYL gegen unendlich gehen. Die herkömmlichen und wohlbekannten Verfahren der Quantisierung lassen keinen Weg erkennen, eine zeitlich asymmetrische, quantisierte Theorie zu erzeugen, wenn die klassische Theorie, auf die diese Verfahren angewendet werden (die etablierte allgemeine Relativitätstheorie oder ihre entsprechenden Modifikationen) ihrerseits zeitlich symmetrisch ist.

Einstein ist auf sein Konzept gekommen aufgrund der folgenden Frage, die er sich gestellt hat: „wenn er sich genau neben einem Lichtstrahl bewegt, wie sieht dann aus seiner Sicht der Lichtstrahl aus?“ Es müsste doch eigentlich so sein, dass der Lichtstrahl eine Folge von stationären Wellen gleicht, in der Zeit erstarrt, m.a.W. der Lichtstrahl müsste bewegungslos erscheinen. Wenn man ihm naheht, sollte man ihn als ruhendes, räumlich oszillierendes, elektromagnetisches Feld wahrnehmen. So etwas scheint es aber nicht zu geben, weder aufgrund der Erfahrung noch aufgrund der Maxwell-Gleichungen, die keine stationären, erstarrten Wellen zulassen. Aufgrund der Maxwell-Gleichungen müssten Elektronen ihre Energie in Sekundenbruchteilen verlieren.

**In any relativistic theory the vacuum, the state of lowest energy, if it exists in „reality“, has to have the energy zero.**

Ebenso muß für freie Teilchen mit Impuls  $\vec{p}$  und Masse  $m$  die Energie  $E = \sqrt{m^2 c^4 + \vec{p}^2 c^2}$  sein.

Es gibt eine durch die ganze Literatur durchgängige Wahl, dem harmonischen Oszillator die Grundzustandsenergie  $\hbar\omega/2$  zuzuordnen. Das wußte Planck bei der Ableitung seiner Strahlungsformel, mit der im Jahr 1900 die Quantenmechanik begann, schon besser: er ordnete Zuständen mit  $n$  Photonen die Energie  $n\hbar\omega$  zu und nicht den Wert  $(n+1/2)\hbar\omega$ , der mit relativistisch kovarianter Beschreibung der Photonen unverträglich ist.

Die Grundzustandsenergie ist grundsätzlich unmeßbar, man verfügt daher über sie so, daß Berechnungen einfach und insbesondere daß sie endlich sind. Energien frei zusammengesetzter Systeme sollten additiv sein. Es gibt in jedem Hohlraum unendlich viele Frequenzen  $\omega_i$  für Photonen. Ordnet man jeder Frequenz einen Beitrag  $\hbar\omega_i/2$  zur Grundzustandsenergie zu, so hat schon der Grundzustand ohne Photonen unendlich viel Energie  $\sum_i \hbar\omega_i/2 = \infty$ .

**Das Mißverständnis, die Grundzustandsenergie liege fest, beginnt in der klassischen Physik.** Die Wahl der Hamiltonfunktion

$$H = \frac{p^2}{2m} + \frac{1}{2}\omega^2 x^2$$

verfügt über die klassisch nicht meßbare Grundzustandsenergie so, daß der Zustand niedrigster Energie, der Punkt  $(x=0, p=0)$  im Phasenraum, die Energie 0 hat. Diese Wahl macht den algebraischen Ausdruck für die potentielle Energie  $V(x)$  einfach, man hätte aber genauso gut  $V(x) = \frac{1}{2}\omega^2 x^2 - \hbar\omega/2$  wählen können.

In the following sections we put together several mathematical concepts. There is nothing new compared to e.g. the great book of R. Penrose, but there is some emphasize on specific mathematical aspects to underline the ideas from above. The intention is to give some guidance to move some next steps forward to the "road to reality", developing the appropriate mathematical model (B). A validation procedure and proof of concept of it the model has to explain/"produce" the fundamental physical constants, which are somehow the gatekeepers to Leibniz's (and Plato's) transcendental (i.e. ideal) world.

All of the following were taken from internet and literature; all references to the internet sources are omitted, as google search offers a really smart way to link directly and fast to any of those topics. A main source about variational theory and the physical concept about forces is the great book [LaC] Lanczos C.

## 1. Vectorial vs. analytical mechanics

Descartes discovered that geometry may be treated as analytically. His geometry assumed the Euclidean structure of space. Riemann's geometry is based on one single differential quantity called "line element".

The significance of this quantity is the distance between two neighboring points of "space", expressed in term of the coordinates and their differentials. The quantity  $ds^2$  has an absolute significance because the distance between two points does not change, no matter what coordinates are employed. It is an "absolute" or "invariant" quantity which is independent of any special reference system.

The science of mechanics has developed along two main lines. One branch starts directly from Newton's law of motion and is called „vectorial mechanics“. All forces are acting on any given particle; its motion is uniquely determined by known forces acting on it at every instance. The basis concern of vectorial mechanics is the analysis and synthesis of forces and velocity. The underlying mechanics is called „vectorial mechanics“. The action of a force is measured by the momentum produced by that force.

Concerning infinitesimals, Newton, in 1669, defines the moment of  $x$  to be an "infinitesimal" increase in the value of a real number,  $x$ . It appears to be indivisible, and thus something of an enigma. Leibniz, in the late 1600s, speaks of monads, ultimate infinitesimal particles from which nature arises. He used this idea in his mathematics, alluding to what we nowadays call the differential  $dx$  as being not 0 but smaller than any finite quantity. In parallel Leibniz developed infinitesimal calculus, already giving non trivial differential calculus in the form

$$d(x + y) = dx + dy \quad d(xy) = xdy + ydx + dx dy = xdy + ydx .$$

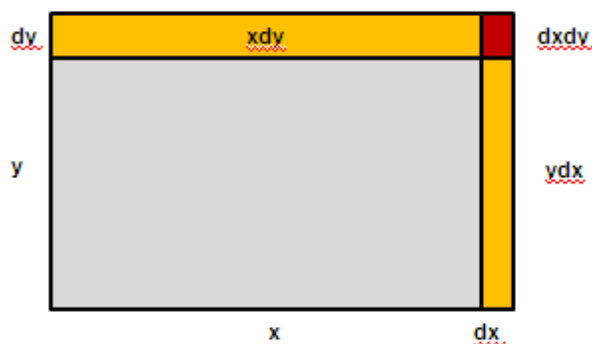

In standard analysis the term  $dx dy$  is neglected as infinitely small of second order (!). This might be an opportunity, when extending k-forms into a non standard framework.

## 1.1 Transformation between Lagrange and Hamiltonian formalism

$$\text{Lagrange --> Hamilton: } L(x, y) \rightarrow H(x, \frac{dL}{dy})$$

The Legendre transformation of  $f(x, y)$  is defined by

$$g := g(x, y) := \psi y - f = y\psi(x, y) - f(x, y)$$

Putting  $\psi := \psi(x, y) := \frac{\partial f(x, y)}{\partial y}$  the differential of  $f(x, y)$  gives

$$df = \frac{\partial f}{\partial x} dx + \frac{\partial f}{\partial y} dy = \frac{\partial f}{\partial x} dx + \psi dy$$

As holds  $\frac{\partial [y\psi(x, y)]}{\partial \psi} = y$  and  $d(\psi y) = \frac{\partial(\psi y)}{\partial \psi} d\psi + \frac{\partial(\psi y)}{\partial y} dy = y d\psi + \psi dy$

It follows  $d(g) = d(\psi y) - df = y d\psi + \psi dy - \left[ \frac{\partial f}{\partial x} dx + \psi dy \right] = y d\psi - \frac{\partial f}{\partial x} dx + (d\psi dy) .$

The product  $d\psi dy$  is neglected to be zero in the standard theory as infinitesimal small of second order compared to  $dx$ . If one would neglected this and calculate in a non-standard way it would result into

$$d(g) = (y + dy)d\psi - \frac{\partial f}{\partial x} dx .$$

Question: Does this change the equivalence of Lagrange and Hamilton formalism in that way, that now the Hamilton integral requires some non-standard variation calculus, which enables modeling also reactive forces (forces of constraints or Zwangskräfte). Zwangskräfte leisten keine Arbeit leisten (zumindest im Standard-Sinne!!) und stehen senkrecht auf der Fläche, auf der sich der Massepunkt bewegen soll ( $\vec{Z}\delta\vec{r} = 0$ ), d.h. die virtuelle Verrückung  $\delta\vec{r}$  steht senkrecht bzgl  $\vec{Z}$ . Zwangskräfte halten einen Massepunkt auf der durch die (holonem-skeleronomen) Nebenbedingungen vorgeschriebenen Bahn; z.B.

rollende Billardkugeln auf einem waagrechten Tisch;

$$m\ddot{\vec{r}} = \vec{F} + \vec{Z} .$$

Nur eingeprägte Kräfte (impressed forces)  $\vec{F}$  können zu echten Beschleunigungen führen.

Leibniz advocated another quantity, replacing Newton's „momentum“ as the proper gauge for the dynamical action of a force, which apart from a factor 2 today is called „kinetic energy“. At the same time he replaced the „force“ by the „work of the force“ (or „work function“). The underlying mechanics is called „analytical mechanics“. The basis concern of

analytical mechanics is the analysis and synthesis of equilibrium and motion on two fundamental scalar quantities, which are „kinetic energy“ and „potential energy“.

A tensor is defined by the components of an invariant differential form.

A differential form of the first order defines a tensor of first order

$$dW = F_1 dx_1 + F_2 dx_2 + \dots + F_n dx_n .$$

The vector  $F_i$  is called the “generalized force”. A differential form of the second order defines a tensor of second order, e.g. the special tensor  $g_{ij}$ , which is called the “metric tensor”, is given by

$$ds^2 = \sum_{i,j} g_{ij} dx_i dx_j .$$

1. There are forces which maintain the given kinematical conditions.

Let  $W$  denote the work,  $d\vec{s} = \vec{v} dt$  and the momentum (Impulse)  $\vec{p} = m\vec{v}$ . The work of forces to a body is the same as the increase of body’s kinetic energy:

$$dW = \vec{F} d\vec{s} = (\vec{F} d\vec{v}) dt = ((m\dot{\vec{v}}) d\vec{v}) dt = d\left(\frac{m}{2} \vec{v}^2\right) = (m\vec{v}) dt = \vec{p} dt =: dT$$

resp.

$$W = \int_{t_1}^{t_2} \vec{F} d\vec{s} = \frac{m}{2} (\vec{v}_2^2 - \vec{v}_1^2) = T_1 - T_2$$

I.e.  $W$  gives all work, which all forces act in the time interval  $[t_1, t_2]$ .

The analytical treatment of mechanics does not require knowledge of these forces.

2. There are forces which come from an external field or from the mutual interaction of particles

The quantity of prime importance for the analytical treatment of mechanics is not a force, but the work done by impressed forces for arbitrary infinitesimal displacements. They are analytically defined as the coefficients of an invariant differential form of the first order, which gives the total work of all the impressed forces for an arbitrary infinitesimal change of the position of the system. The forces acting on a mechanical system fall automatically into two categories:

A. it is possible that all one can say about the work  $dW$  is that it is a differential form of the first order

B. it is possible that  $dW$  turns out to be a true differential of a certain “work function”  $U = U(q_1, q_2, \dots, q_n)$  (which is the usual one in analytical problems), i.e.  $dW = dU$  with

$$F_i = -\frac{\partial U}{\partial q_i}.$$

There are forces in the nature which are derivable from a time-dependent work function  $U = U(q_1, q_2, \dots, q_n)$ , i.e. the generalized force possesses a work function without being conservative. An electronically charged particle revolving in a cyclotron returns to the same point with increased kinetic energy, so that energy is not conserved. This is not because the work does not exist, but because the work function is time-dependent. On the other hand, a generalized force may have no work function and still satisfy the conservation of energy, as for example the force which maintains rolling.

There are two distinctive names for forces which are derivable from a scalar quantity, irrespective of whether they are conservative or not. The name “monogenic” (which means “single-generated”) for the category of forces, while forces which are not derivable from a scalar product, such as a friction, are called “polygenic”. The work function associated with a monogenic force is in the most general case a function of the coordinates and the velocities:

$$U = U(q_1, q_2, \dots, q_n; \dot{q}_1, \dot{q}_2, \dots, \dot{q}_n; t)$$

For example the electro-magnetic force of Lorentz, which acts on a charged particle in the presence of an electronic and magnetic field, is derivable from a work function of this kind. Such forces are still susceptible to the variation treatment.

## 1.2 Variational Principle

### The principle of virtual work for reversible displacements

A particle is in equilibrium if the resulting force acting on that particle is zero: this form of mechanics isolates the particle and replaces all constraints by forces. The inconvenience of this procedure is obvious if one thinks of such a simple problem as the equilibrium of a lever, which is composed of infinity of particles and infinity of inner forces acting between them. The analytical treatment can dispense with all these forces and take only the external force into account (in the case of the lever the force of gravity. This is accomplished by performing only such virtual displacements as are in harmony with the given constraints. In variational treatment of mechanics the „forces of constraints“ (Zwangskräfte, reactive forces; e.g. Billardtisch gegenüber rollender Billiardkugel auf waagrechttem Tisch)), which maintain certain given kinematical conditions are neglected. Only the work of the „impressed forces“ needs to be taken into account. One may eliminate the action of the inner forces, since the virtual displacements applied to the system are in harmony with the given kinematical conditions.

The principle of virtual work demands that for the state of equilibrium the work of the impressed forces is zero for any infinitesimal variation of the configuration of the system which is in harmony with the given kinematical constraints. For monogenic forces, this leads to the condition that, for equilibrium, the potential energy shall be stationary with respect to all kinematical permissible variations.

The general kinematical possibilities of a rigid body are translation and rotation. The possibility of translation requires the sum of all forces to vanish, and the possibilities of rotation require the sum of all moments to vanish for equilibrium.

D'Alembert's principle introduces a new force, the force of inertia, defined as the negative of the product of mass times acceleration. If this force is added to the impressed forces we have equilibrium, which means that the principle of virtual work is satisfied. The principle of virtual work is thus extended from the realm of static to the realm of dynamics.

D'Alembert's principle requires a polygenic quantity in forming the virtual work of the forces of inertia; hence it cannot provide the same facilities in the analytical use of curvilinear coordinates as the principle of action. However, in problems which involve the use of kinematical variables (non-holonomic velocities) and the transformation to moving reference systems, d'Alembert's principle is eminently useful.

In order to make the reference to the philosophy of Leibniz we recall:

- "work" is no property of the body, the "work" is related to the interval  $[t_1, t_2]$

- "kinetic energy"  $T := m\vec{v}^2 / 2$  is a property of the body, which characterizes its actual momentum.

### 1.3 Lagrange and Hamiltonian Principle

Euler and Lagrange discovered the principle of „least action“. In the Lagrange formulation it's about an analysis of the position and the velocity of a particle, i.e. it's about equations of motions. The Hamiltonian formulation of this principle asserts that the actual motion realized in nature is that particular motion, for which this action assumes its smallest value. Its fundamental objects are the position and the momentum of a particle. The Noether theorem states, that if there is a continuous symmetry transformation, which keeps the action integral invariant, then there exists conservation variable.

Lagrange formalism  $\leftrightarrow$  Hamiltonian formalism

(\*) *Equation of motions*  $\leftrightarrow$  *Action principle*

*Causal*  $\leftrightarrow$  *purpose*

The equivalence of (\*) breaks down at the quantum level. Quantum mechanically, there is a fundamental difference between the two, with the equations of motion being only an approximation to the actual quantum behavior of matter. Thus *the action principle is the only acceptable framework for quantum mechanics*: classical mechanics assumes that a particle



executes just one path between two points based either on the equation of motion or on the minimization of the action. By contrast, quantum mechanics sums the contributions of probability functions (based on action) for all possible paths between two points. Although the classical path is the one most favored, in principle all possible paths contribute to the path integral. Thus, the action principle is more fundamental than the equations of motion at the quantum level.

The formalism of path integrals is so versatile that it can accommodate both first quantized point particles and second quantized gauge fields with equal ease.

The mathematical problem of minimizing an integral is dealt with in a special branch of the calculus, called „calculus of variation“. The variational theory, founded on Euler and Lagrange, bases everything on the two scalar quantities, „kinetic energy“ and „potential energy“. The variational approach assumes that the acting forces are derivable from a scalar quantity, the „work function“. Forces of frictional nature, which have no work function, are outside the realm of variational principles.

$$W[q] = \int_{t_1}^{t_2} L(q(t), \dot{q}(t), t) dt \quad \leftrightarrow \quad W[q] = \int_{t_1}^{t_2} [\dot{q}(t)q(t) - L(q(t), \dot{q}(t), t)] dt$$

A variation means an infinitesimal change, in analogy with the d-process of ordinary calculus. However, contrary to the ordinary d-process, this infinitesimal change is not caused by the actual change of an independent variable, but is imposed on a set of variables as a kind of mathematical experiment. The term „virtual“ indicates that a displacement was intentionally made in any kinematically admissible manner. Such a virtual and infinitesimal change of position is called a „variation“ of the position. A variation of the position is at disposal, but the corresponding change of the function (e.g. potential energy), which is called the „variation of the function“ is not at disposal.

The principle of virtual work demands that for the state of equilibrium the work of the impressed forces is zero for any infinitesimal variation of configuration of the system which is in harmony with the given kinematical constraints. For monogenic forces, this leads to the condition that, for equilibrium, the potential energy shall be stationary with respect to all kinematically permissible variations.

Since in problems involving the variation of definite integrals both types of change ( $\delta$  and  $d$ ) have to be considered simultaneously, the distinction is of vital importance.

## 2. Distribution solution of the 1D wave equation

The „vibration string“ equation

$$u_{tt} - k^2 u_{xx} = 0$$

has a solution  $u(x,t) = f(x-kt)$  for any function of one variable  $f$ , which has the physical interpretation of a „traveling wave“ with „shape“  $f(x)$  moving at velocity  $k$ .

There is no physical reason for the “shape” to be differentiable, but if it is not, the differential equation is not satisfied at some points. In order to not throw away physically meaningful solutions because of technicalities, the concept of distributions can be applied.

If the equation above is also meaningful, if  $u$  is a distribution, then  $u$  is called a weak solution of it. If  $u$  is twice continuously differentiable and the equation holds, one calls  $u$  a strong or classical solution. Each classical solution is a weak solution. In case of the equation above it's also the other way around. The same is NOT TRUE for the elliptic Laplace equation (counter example is the classical solution  $u(x,y) := \log(x^2 + y^2)$ ), but not a weak solution as it holds there  $\Delta \log(x^2 + y^2) = 4\pi\delta$ . In order to see this we show that for  $u(x,y) := f(x-kt) \in L^1_{loc}(R^2)$  it holds

$$(*) \quad (u_{tt} - k^2 u_{xx}, \varphi) = 0 .$$

From the following identities

$$i) \quad (u_{tt}, \varphi) = (u, \varphi_{tt}) = \iint f(x-kt) \varphi_{tt} dx dt$$

$$ii) \quad (u_{xx}, \varphi) = (u, \varphi_{xx}) = \iint f(x-kt) \varphi_{xx} dx dt$$

it follows

$$(u_{tt} - k^2 u_{xx}, \varphi) = \iint f(x-kt) [\varphi_{tt} - k^2 \varphi_{xx}] dx dt .$$

Substituting the variable in the form  $y = x - kt$  and  $z = x + kt$  means

$$\frac{\partial(y,z)}{\partial(x,t)} = \begin{pmatrix} 1 & -k \\ 1 & k \end{pmatrix} \text{ and } 2k dx dt = dy dz .$$

From this it follows

$$(u_{tt} - k^2 u_{xx}, \varphi) = -2k \iint f(y) \varphi_{yz} dz dy = -2k \int_{-\infty}^{\infty} f(y) \left( \int_{-\infty}^{\infty} \varphi_{yz} dz \right) dy .$$

As  $\int_{-\infty}^{\infty} \varphi_{yz} dz = \varphi_y \Big|_{z=-\infty}^{z=\infty} = 0$  this proves (\*) above.

### 3. Why Strings?

While the Standard Model has been very successful in describing most of the phenomena that we can experimentally investigate with the current generation of particle accelerators, it leaves many unanswered questions about the fundamental nature of the universe. The goal of modern theoretical physics has been to find a "unified" description of the universe. This has historically been a very fruitful approach. For example Einstein-Maxwell theory unifies the forces of electricity and magnetism into the electromagnetic force. The Nobel prize winning work of Glashow, Salam, and Weinberg successfully showed that the electromagnetic and weak forces can be unified into a single electroweak force. There is actually some pretty strong evidence that the forces of the Standard Model should all unify as well. When we examine how the relative strengths of the strong force and electroweak force behave as we go to higher and higher energies, we find that they become the same at an energy of about  $10^{16} \text{ GeV}$ . In addition the gravitational force should become equally important at an energy of about  $10^{19} \text{ GeV}$ .

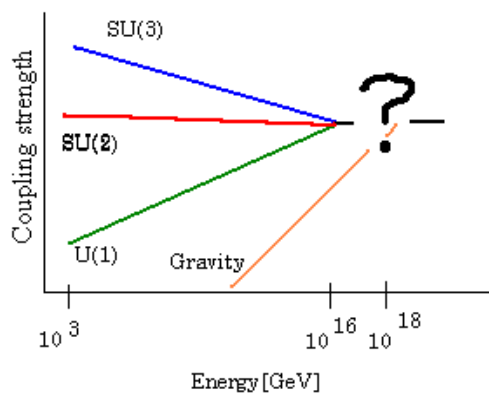

The goal of string theory is to explain the "?" in the above diagram.

The characteristic energy scale for quantum gravity is called the *Planck Mass*, and is given in terms of Planck constant, the speed of light, and Newton's constant,

$$M_{pl} = \sqrt{\hbar c / G_N} = 1.22 * 10^{19} \text{ GeV} / c^2$$

Physics at this high energy scale describes the universe as it existed during the first moments of the Big Bang. These high energy scales are completely beyond the range which can be created in the particle accelerators we currently have (or will have in the foreseeable future.) Most of the physical theories that we use to understand the universe that we live in also break down at the Planck scale. However, string theory shows unique promise in being able to describe the physics of the Planck scale and the Big Bang.

In its final form string theory should be able to provide answers to answer questions like:

- Where do the four forces that we see come from?
- Why do we see the various types of particles that we do?
- Why do particles have the masses and charges that we see?
- Why do we live in 4 space-time dimensions?
- What is the nature of space-time and gravity?

## String Basics

We are used to thinking of fundamental particles (like electrons) as point-like 0-dimensional objects. A generalization of this is fundamental strings which are **1-dimensional objects**. They have no thickness but do have a length, typically  $10^{-33}$  cm. This is very small compared to the length scales that we can reasonably measure, so these strings are so small that they practically look like point particles. However their stringy nature has important implications as we will see.

Strings can be open or closed. As they move through space-time they sweep out an imaginary surface called a world-sheet.

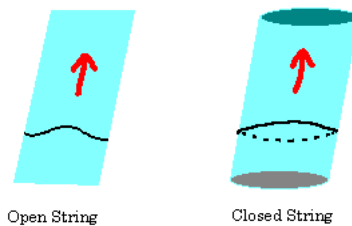

These strings have certain vibrational modes which can be characterized by various quantum numbers such as mass, spin, etc. The basic idea is that each mode carries a set of quantum numbers that correspond to a distinct type of fundamental particle. This is the ultimate unification: all the fundamental particles we know can be described by one object, a string!. A very loose analogy can be made with say, a violin string. The vibrational modes are like the harmonics or notes of the violin string, and each type of particle corresponds to one of these notes.

As an example let's consider a closed string mode which looks like:



This mode is characteristic of a spin-2 massless **graviton** (the particle that mediates the force of gravity). This is one of the most attractive features of string theory. It naturally and inevitably includes gravity as one of the fundamental interactions.

Strings interact by splitting and joining. For example the annihilation of two closed strings into a single closed string occurs with an interaction that looks like:

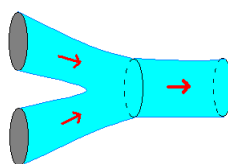

Notice that the worldsheet of the interaction is a smooth surface. This essentially accounts for another nice property of string theory. It is not plagued by infinities in the way that point

particle quantum field theories are. The analogous Feynman diagram in a point particle field theory is:

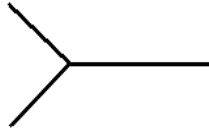

Notice that the interaction point occurs at a topological singularity in the diagram (where the 3 world-lines intersect). This leads to a break down of the point particle theory at high energies.

If we glue two of the basic closed string interactions together, we get a process by which two closed strings interact by joining into an intermediate closed string which splits apart into two closed strings again:



This is the leading contribution to this process and is called a tree level interaction. To compute quantum mechanical amplitudes using **perturbation theory** we add contributions from higher order quantum processes. Perturbation theory provides good answers as long as the contributions get smaller and smaller as we go to higher and higher orders. Then we only need to compute the first few diagrams to get accurate results. In string theory, higher order diagrams correspond to the number of holes (or handles) in the world sheet.

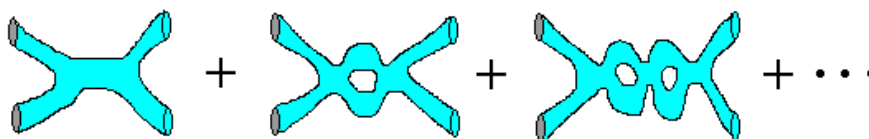

The nice thing about this is that at each order in perturbation theory there is only one diagram. In point particle field theories the number of diagrams grows exponentially at higher orders. The bad news is that extracting answers from diagrams with more than about two handles is very difficult due to the complexity of the mathematics involved in dealing with these surfaces. Perturbation theory is a very useful tool for studying the physics at weak coupling, and most of our current understanding of particle physics and string theory is based on it. However it is far from complete. The answers to many of the deepest questions will only be found once we have a complete non-perturbative description of the theory.

## D-branes

Strings can have various kinds of boundary conditions. For example closed strings have periodic boundary conditions (the string comes back onto itself). Open strings can have two different kinds of boundary conditions called Neumann and Dirichlet boundary conditions. With Neumann boundary conditions the endpoint is free to move about but no momentum flows out. With Dirichlet boundary conditions the endpoint is fixed to move only on some manifold. This manifold is called a D-brane or **Dp-brane** ('p' is an integer which is the number of spatial dimensions of the manifold). For example we see open strings with one or both endpoints fixed on a 2-dimensional **D-brane** or D2-brane:



D-branes can have dimensions ranging from -1 to the number of spatial dimensions in our spacetime. For example superstrings live in a 10-dimensional spacetime which has 9 spatial dimensions and one time dimension. Therefore the D9-brane is the upper limit in superstring theory. Notice that in this case the endpoints are fixed on a manifold that fills all of space so it is really free to move anywhere and this is just a Neumann boundary condition! The case  $p = -1$  is when all the space and time coordinates are fixed, this is called an *instanton* or *D-instanton*. When  $p = 0$  all the spatial coordinates are fixed so the endpoint must live at a single point in space, therefore the D0-brane is also called a D-particle. Likewise the D1-brane is also called a D-string. Incidentally the suffix 'brane' is borrowed from the word 'membrane' which is reserved for 2-dimensional manifolds or 2-branes!

D-branes are actually dynamical objects which have fluctuations and can move around. This was first shown by physicist Joseph Polchinski. For example they interact with gravity. In the diagram below we see one way in which a closed string (graviton) can interact with a D2-brane. Notice how the closed string becomes an open string with endpoints on the D-brane at the intermediate point in the interaction.

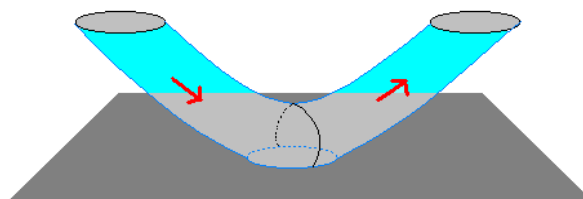

We now see that string theory is more than just a theory of strings!

## Supersymmetric Strings

There are two types of particles in nature - fermions and bosons. A fundamental theory of nature must contain both of these types. When we include fermions in the worldsheet theory of the string, we automatically get a new type of symmetry called supersymmetry which relates bosons and fermions. Fermions and bosons are grouped together into

supermultiplets which are related under the symmetry. This is the reason for the "super" in "superstrings".

A consistent quantum field theory of superstrings exists only in **10 spacetime dimensions!** Otherwise there are quantum effects which render the theory inconsistent or 'anomalous'. In 10 spacetime dimensions the effects can precisely cancel leaving the theory anomaly free. It may seem to be a problem to have 10 spacetime dimensions instead of the 4 spacetime dimensions that we observe, but we will see that in getting from 10 to 4 we actually find some interesting physics.

In terms of weak coupling perturbation theory there appear to be only **five** different consistent superstring theories known as **Type I SO(32), Type IIA, Type IIB, SO(32) Heterotic and E8 x E8 Heterotic.**

	Type IIB	Type IIA	E8 x E8 Heterotic	SO(32) Heterotic	Type I SO(32)
<b>String Type</b>	Closed	Closed	Closed	Closed	Open (& closed)
<b>10d Supersymmetry</b>	N=2 (chiral)	N=2 (non-chiral)	N=1	N=1	N=1
<b>10d Gauge groups</b>	none	none	E8 x E8	SO(32)	SO(32)
<b>D-branes</b>	- 1,1,3,5,7	0,2,4,6,8	none	none	1,5,9

### **Type I SO(32):**

This is a theory which contains open superstrings. It has one (N=1) supersymmetry in 10 dimensions. Open strings can carry gauge degrees of freedom at their endpoints, and cancellation of anomalies uniquely constrains the gauge group to be SO(32). It contains D-branes with 1, 5, and 9 spatial dimensions.

### **Type IIA:**

This is a theory of closed superstrings which has two (N=2) supersymmetries in ten dimensions. The two gravitini (superpartners to the graviton) move in opposite directions on the closed string world sheet and have opposite chiralities under the 10 dimensional Lorentz group, so this is a non-chiral theory. There is no gauge group. It contains D-branes with 0, 2, 4, 6, and 8 spatial dimensions.

### **Type IIB:**

This is also a closed superstring theory with N=2 supersymmetry. However in this case the two gravitini have the same chiralities under the 10 dimensional Lorentz group, so this is a chiral theory. Again there is no gauge group, but it contains D-branes with -1, 1, 3, 5, and 7 spatial dimensions.

### **SO(32) Heterotic:**

This is a closed string theory with worldsheet fields moving in one direction on the world sheet which have a supersymmetry and fields moving in the opposite direction which have no supersymmetry. The result is N=1 supersymmetry in 10 dimensions. The non-supersymmetric fields contribute massless vector bosons to the spectrum which by anomaly cancellation are required to have an SO(32) gauge symmetry.

### **E8 x E8 Heterotic:**

This theory is identical to the SO(32) Heterotic string, except that the gauge group is E8 X E8 which is the only other gauge group allowed by anomaly cancellation.

We see that the Heterotic theories don't contain D-branes. They do however contain a fivebrane soliton which is not a D-brane. The IIA and IIB theories also contain this fivebrane soliton in addition to the D-branes. This fivebrane is usually called the "Neveu-Schwarz fivebrane" or "NS fivebrane".

It is worthwhile to note that the **E8 x E8 Heterotic** string has historically been considered to be the most promising string theory for describing the physics beyond the Standard Model. It was discovered in 1987 by Gross, Harvey, Martinec, and Rohm and for a long time it was thought to be the only string theory relevant for describing our universe. This is because the  $SU(3) \times SU(2) \times U(1)$  gauge group of the standard model can fit quite nicely within one of the E8 gauge groups. The matter under the other E8 would not interact except through gravity, and might provide an answer to the Dark Matter problem in astrophysics. Due to our lack of a full understanding of string theory, answers to questions such as how is supersymmetry broken and why are there only 3 generations of particles in the Standard Model have remained unanswered. Most of these questions are related to the issue of compactification (discussed on the next page). What we have learned is that string theory contains all the essential elements to be a successful unified theory of particle interactions, and it is virtually the only candidate which does so. However, we don't yet know how these elements specifically come together to describe the physics that we currently observe.

## Extra Dimensions

Superstrings live in a 10-dimensional spacetime, but we observe a 4-dimensional spacetime. Somehow we need to link the two if superstrings are to describe our universe. To do this we curl up the extra 6 dimensions into a small compact space. If the size of the compact space is of order the string scale ( $10^{-33}$  cm) we wouldn't be able to detect the presence of these extra dimensions directly - they're just too small. The end result is that we get back to our familiar (3+1)-dimensional world, but there is a tiny "ball" of 6-dimensional space associated with every point in our 4-dimensional universe. This is shown in an extremely schematic way in the following illustration:

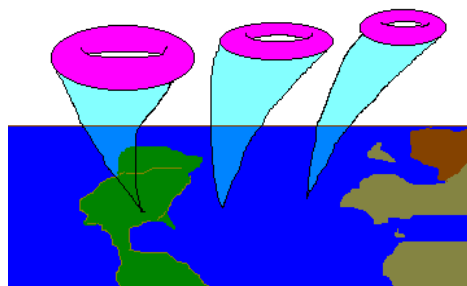

This is actually a very old idea dating back to the 1920's and the work of Kaluza and Klein. This mechanism is often called **Kaluza-Klein theory** or compactification. In the original work of Kaluza it was shown that if we start with a theory of general relativity in 5-spacetime dimensions and then curl up one of the dimensions into a circle we end up with a 4-dimensional theory of general relativity plus electromagnetism! The reason why this works is that electromagnetism is a **U(1) gauge theory**, and U(1) is just the group of rotations around a circle. If we assume that the electron has a degree of freedom corresponding to point on a circle, and that this point is free to vary on the circle as we move around in spacetime, we find that the theory must contain the photon and that the electron obeys the equations of motion of electromagnetism (namely **Maxwell's equations**). The Kaluza-Klein mechanism simply gives a geometrical explanation for this circle: it comes from an actual fifth dimension that has been curled up. In this simple example we see that even though the compact dimensions maybe too small to detect directly, they still can have profound physical



implications. Incidentally the work of Kaluza and Klein leaked over into the popular culture launching all kinds of fantasies about the "Fifth dimension"!

How would we ever really know if there were extra dimensions and how could we detect them if we had particle accelerators with high enough energies? From quantum mechanics we know that if a spatial dimension is periodic the momentum in that dimension is quantized,  $p = n / R$  ( $n=0,1,2,3,\dots$ ), whereas if a spatial dimension is unconstrained the momentum can take on a continuum of values. As the radius of the compact dimension decreases (the circle becomes very small) then the gap between the allowed momentum values becomes very wide. Thus we have a Kaluza Klein tower of momentum states.

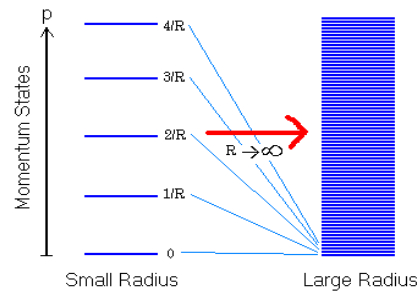

If we take the radius of the circle to be very large (the dimension is de-compactifying) then the allowed values of the momentum become very closely spaced and begin to form a continuum. These Kaluza-Klein momentum states will show up in the mass spectrum of the uncompactified world. In particular, a massless state in the higher dimensional theory will show up in the lower dimensional theory as a tower of equally spaced massive states just as in the picture shown above. A particle accelerator would then observe a set of particles with masses equally spaced from each other. Unfortunately, we'd need a very high energy accelerator to see even the lightest massive particle.

Strings have a fascinating extra property when compactified: they can wind around a compact dimension which leads to winding modes in the mass spectrum. A closed string can wind around a periodic dimension an integral number of times. Similar to the Kaluza-Klein case they contribute a momentum which goes as  $p = w / R$  ( $w=0,1,2,\dots$ ). The crucial difference here is that this goes the other way with respect to the radius of the compact dimension,  $R$ . So now as the compact dimension becomes very small these winding modes are becoming very light!

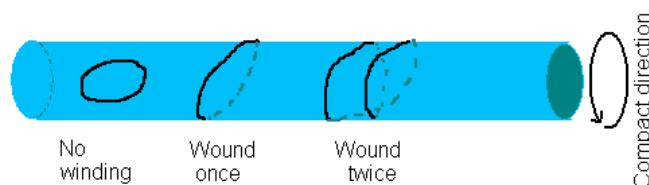

Now to make contact with our 4-dimensional world we need to compactify the 10-dimensional superstring theory on a 6-dimensional compact manifold. Needless to say, the Kaluza Klein picture described above becomes a bit more complicated. One way could simply be to put the extra 6 dimensions on 6 circles, which is just a 6-dimensional Torus. As it turns out this would preserve too much supersymmetry. It is believed that some supersymmetry exists in our 4-dimensional world at an energy scale above 1 TeV (this is the focus of much of the current and future research at the highest energy accelerators around the world!). To preserve the minimal amount of supersymmetry,  $N=1$  in 4 dimensions, we need to compactify on a special kind of 6-manifold called a **Calabi-Yau manifold**. The properties of the Calabi-Yau manifold can have important implications for low energy physics such as the types of particles observed, their masses and quantum numbers, and the number of generations. One of the outstanding problems in the field has been the fact

that there are many many Calabi-Yau manifolds (thousands upon thousands?) and we have no way of knowing which one to use. In a sense we started with a virtually unique 10-dimensional string theory and have found that possibilities for 4-dimensional physics are far from unique, at least at the level of our current (and incomplete) understanding. The long-standing hope of string theorists is that a detailed knowledge of the full non-perturbative structure of the theory, will lead us to an explanation of how and why our universe flowed from the 10-dimensional physics that probably existed during the high energy phase of the Big Bang, down to the low energy 4-dimensional physics that we observe today. Possibly we will find a unique Calabi-Yau manifold that does the trick. Some important work of Andrew Strominger has shown that Calabi-Yau manifolds can be continuously connected to one another through **conifold transitions** and that we can move between different **Calabi-Yau manifolds** by varying parameters in the theory. This suggests the possibility that the various 4-dimensional theories arising from different Calabi-Yau manifolds might actually be different phases of a single underlying theory.

## String Duality

The five superstring theories appear to be very different when viewed in terms of their descriptions in weakly coupled perturbation theory. In fact they are all related to each other by various string dualities. We say two theories are dual when they both describe the same physics.

The first kind of duality that we will discuss is called **T-duality**. This duality relates a theory which is compactified on a circle with radius  $R$ , to another theory compactified on a circle with radius  $1/R$ . Therefore when one theory has a dimension curled up into a small circle, the other theory has a dimension which is on a very large circle (it is barely compactified at all) but they both describe the same physics! The Type IIA and Type IIB superstring theories are related by T-duality and the  $SO(32)$  Heterotic and  $E8 \times E8$  Heterotic theories are also related by T-duality.

The next duality that we will consider is called **S-duality**. Simply put, this duality relates the strong coupling limit of one theory to the weak coupling limit of another theory. (Note that the weak coupling descriptions of both theories can be quite different though.) For example the  $SO(32)$  Heterotic string and the Type I string theories are S-dual in 10 dimensions. These means that the strong coupling limit of the  $SO(32)$  Heterotic string is the weakly coupled Type I string and visa versa. One way to find evidence for a duality between strong and weak coupling is to compare the spectrum of light states in each picture and see if they agree. For example the Type I string theory has a D-string state that is heavy at weak coupling, but light at strong coupling. This D-string carries the same light fields as the worldsheet of the  $SO(32)$  Heterotic string, so when the Type I theory is very strongly coupled this D-string is becomes very light and we see the weakly coupled Heterotic string description emerging. The other S-duality in 10 dimensions is the self duality of the IIB string: the strong coupling limit of the IIB string is another weakly coupled IIB string theory. The IIB theory also has a D-string (with more supersymmetry than the Type I D-string and hence different physics) which becomes a light state at strong coupling, but this D-string looks like another fundamental Type IIB string.

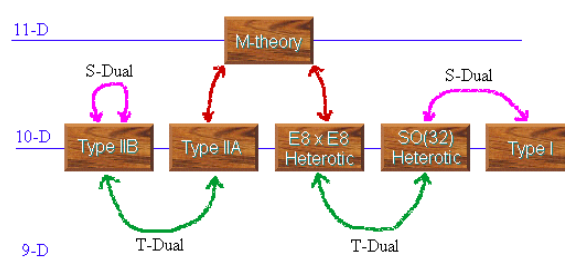

In 1995, physicist and mathematician Edward Witten pioneered the idea that Type IIA and E8 x E8 string theories are related to each other through a new 11-dimensional theory which he called "M-theory". This revelation provided the missing link that related all of the superstring theories through a chain of dualities. The dualities between the various string theories provide strong evidence that they are simply different descriptions of the same underlying theory. Each description has its own regime of validity, and in certain limits another description takes over just when the original one is breaks down.

### What is this "M-theory" shown above?

#### M-theory

M-theory is described at low energies by an effective theory called 11-dimensional supergravity. This theory has a membrane and 5-branes as solitons, but no strings. How can we get the strings that we've come to know and love from this theory? We can compactify the 11-dimensional M-theory on a small circle to get a 10-dimensional theory. If we take a membrane with the topology of a torus and wrap one of its dimensions on this compact circle, the membrane will become a closed string! In the limit where the circle becomes very small we recover the Type IIA superstring.

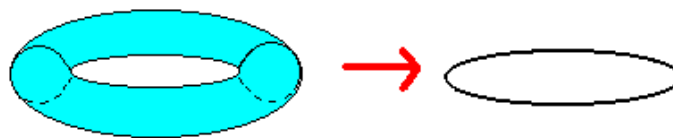

How do we know that M-theory on a circle gives the IIA superstring, and not the IIB or Heterotic superstrings? The answer to this question comes from a careful analysis of the massless fields that we get upon compactification of 11-dimensional supergravity on a circle. Another easy check is that we can find an M-theory origin for the D-brane states unique to the IIA theory. Recall that the IIA theory contains D0,D2,D4,D6,D8-branes as well as the NS fivebrane. The following table summarizes the situation:

M-theory on circle	IIA in 10 dimensions
Wrap membrane on circle	IIA superstring
Shrink membrane to zero size	D0-brane
Unwrapped membrane	D2-brane
Wrap fivebrane on circle	D4-brane
Unwrapped fivebrane	NS fivebrane

The two that have been left out are the D6 and D8-branes. The D6-brane can be interpreted as a "Kaluza Klein Monopole" which is a special kind of solution to 11-dimensional supergravity when it's compactified on a circle. The D8-brane doesn't really have clear interpretation in terms of M-theory at this point in time; that's a topic for current research!

We can also get a consistent 10-dimensional theory if we compactify M-theory on a small line segment. That is, take one dimension (the 11-th dimension) to have a finite length. The endpoints of the line segment define boundaries with 9 spatial dimensions. An open membrane can end on these boundaries. Since the intersection of the membrane and a boundary is a string, we see that the 9+1 dimensional worldvolume of the each boundary can contain strings which come from the ends of membranes. As it turns out, in order for anomalies to cancel in the supergravity theory, we also need each boundary to carry an E8

gauge group. Therefore as we take the space between the boundaries to be very small we're left with a 10-dimensional theory with strings and an  $E_8 \times E_8$  gauge group. This is the  $E_8 \times E_8$  heterotic string!

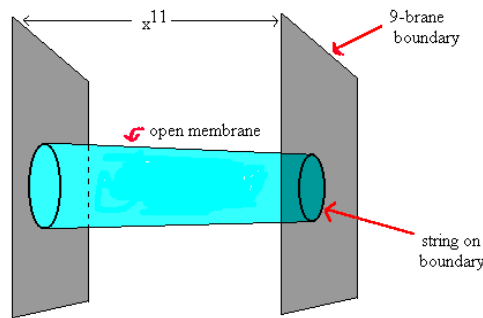

So given this new phase 11-dimensional phase of string theory, and the various dualities between string theories, we're led to the very exciting prospect that there is only a single fundamental underlying theory -- **M-theory**. The five superstring theories and 11-D Supergravity can be thought of as classical limits. Previously, we've tried to deduce their quantum theories by expanding around these classical limits using perturbation theory. Perturbation has its limits, so by studying non-perturbative aspects of these theories using dualities, supersymmetry, etc. we've come to the conclusion that there only seems to be one unique quantum theory behind it all. This uniqueness is very appealing, and much of the work in this field will be directed toward formulating the full quantum M-theory.

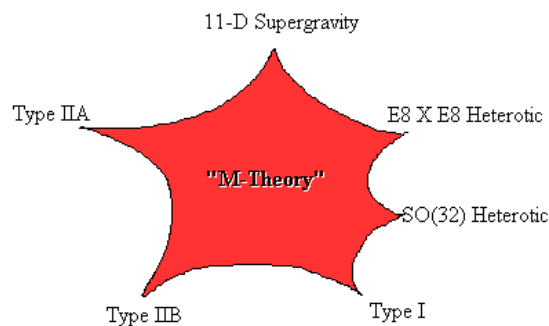

## Black Holes

The classical description of gravity known as General Relativity, contains solutions which are called "black holes". There are many different kinds of black hole solutions but they share some common characteristics. The event horizon is a surface in spacetime which, loosely speaking, divides the inside of the black hole from the outside. The gravitational attraction of a black hole is so strong that any object that crosses the event horizon, including light, can never escape out of the black hole. Classical black holes are therefore relatively featureless, but they can be described by a set of observable parameters such as mass, charge, and angular momentum.

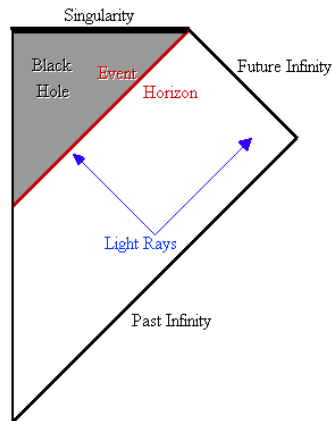

A **Penrose Diagram** shows the global causal structure of a space-time. It is a space-time diagram in which all light rays travel in 45 degree angles. Therefore massive particles must travel on trajectories that lie within the light cone which sits at every point in the diagram. In the following diagram the causal structure of a spherically symmetric "Schwarzschild" type black hole is shown. Only radial and time directions are represented while angular directions are suppressed. Once inside the event horizon, the only way for a trajectory to escape to future infinity is if it travelled faster than light which is not possible according to the laws of special relativity. Therefore all physical trajectories inevitably lead to the singularity.

A Penrose diagram is not meant to accurately portray distances, only causal structure.

Black holes turn out to be important "laboratories" in which to test string theory, because the effects of quantum gravity turn out to be important even for large macroscopic holes. Black holes aren't really "black" since they radiate! Using semi-classical reasoning, Stephen Hawking showed black holes emit a thermal spectrum of radiation at their event horizon. Since string theory is, among other things, a theory of quantum gravity, it should be able to describe black holes in a consistent way. In fact there are black hole solutions which satisfy the string equations of motion. These equations of motion resemble the equations of general relativity with some extra matter fields coming from string theory. Superstring theories also have some special black hole solutions which are themselves super-symmetric, in that they preserve some super-symmetry.

One of the most dramatic recent results in string theory is the derivation of the **Bekenstein-Hawking entropy** formula for black holes obtained by counting the microscopic string states which form a black hole. Bekenstein noted that black holes obey an "area law",  $dM = K dA$ , where 'A' is the area of the event horizon and 'K' is a constant of proportionality. Since the total mass 'M' of a black hole is just its rest energy, Bekenstein realized that this is similar to the thermodynamic law for entropy,  $dE = T dS$ . Hawking later performed a semi-classical calculation to show that the temperature of a black hole is given by  $T = 4 k$  [where k is a constant called the "surface gravity"]. Therefore the entropy of a black hole should be written as  $S = A/4$ . Physicists Andrew Strominger and Cumrun Vafa, showed that this exact entropy formula can be derived microscopically (including the factor of 1/4) by counting the degeneracy of quantum states of configurations of strings and D-branes which correspond to black holes in string theory. This is compelling evidence that D-branes can provide a short distance weak coupling description of certain black holes! For example, the class of black holes studied by Strominger and Vafa are described by 5-branes, 1-branes and open strings traveling down the 1-brane all wrapped on a 5-dimensional torus, which gives an effective one dimensional object -- a black hole.

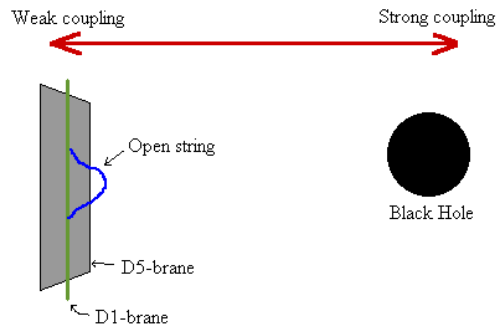

Hawking radiation can also be understood in terms of the same configuration, but with open strings traveling in both directions. The open strings interact, and radiation is emitted in the form of closed strings. The system decays into the configuration shown above.

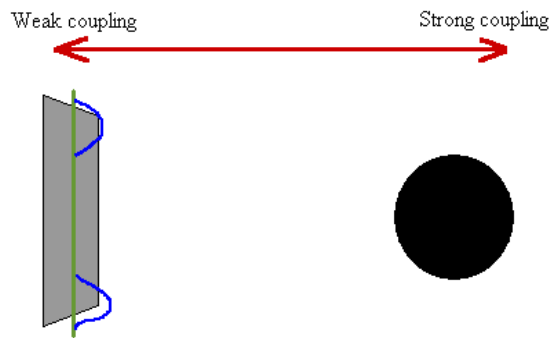

Explicit calculations show that for certain types of supersymmetric black holes, the string theory answer agrees with the semi-classical supergravity answer including non-trivial frequency dependent corrections called greybody factors. This is more evidence that string theory is a consistent and accurate fundamental theory of quantum gravity.

## Summary

Superstring theory is a very exciting area of study because it has the serious potential to be the right theory for describing the fundamental nature of our universe. All the elements are in there: quantum physics, bosons, fermions, gauge groups, and gravity. In the last several years there has been great progress in understanding the overall structure of the theory including D-branes and string duality. String theory has been applied with great success to the study of black hole physics and quantum gravity. However, there is much work yet to be done.

The “birthday” of the Superstring theory happened in 1968, when Gabriel Veneziano and Mahiko Suzuki came across using the Euler beta function to describe interactions of elementary particles:

Consider an elastic scattering process with 2 incoming spinless particles of transverse momenta  $p_1, p_2$ , outgoing particles of momenta  $-p_3, -p_4$ . With a metric with signature  $\{-, +, +, +, \dots +\}$  the mass squared of a particle is  $m^2 = -p^2$ . The conventional Mandelstam variables are defined as

$$s = -(p_1 + p_2)^2, \quad t = -(p_2 + p_3)^2, \quad u = -(p_1 + p_3)^2.$$

which obey the one identity

$$s + t + u = \sum m_i^2.$$

The largest  $J = \alpha(s)$  value at given  $s$  with  $s = m^2 = (2p)^2$  the square of the energy in the center of mass frame and the angular momentum  $J = 2p \frac{r}{2} = pr$  formed the so-called “leading trajectory”. Experimentally, it was discovered that the leading trajectories were almost linear in  $s$ .

In the field theory of the weak interactions the simplest model amplitude  $A(s, t)$  is constructed as a sum of s-channel & t-channel input diagrams in the form

$$A(s, t) = A(t, s) = \frac{\Gamma(-\alpha(s))\Gamma(-\alpha(t))}{\Gamma(-\alpha(s) - \alpha(t))} = B(-\alpha(s), -\alpha(t)) = \sum_{j=0}^{\infty} \binom{\alpha(t) + j}{j} \frac{1}{j - \alpha(s)},$$

that shows poles, where the resonance of the leading (Regge) trajectories  $\alpha(s)$  is necessarily linear in  $s$ , i.e.  $\alpha(x) = \alpha'x - \alpha(0)$  with the “daughter trajectories”  $\alpha(s) = \alpha's - \alpha(0) - n$ , (postulated by Veneziano), to achieve, that the formula is physically acceptable.  $\alpha(0)$  depends on the quantum numbers such as strangeness and baryon number, but  $\alpha'$  appeared to be universal, approximately, i.e.

$$\alpha' \approx 1 \left[ \frac{1}{\text{GeV}} \right]^2 = \text{const} \tan t \quad \text{Regge slope}$$

$$\alpha(x) = \alpha'x - \alpha(0) \quad \text{linear Regge trajectory.}$$

A resonance occurs at those  $s$  values where  $\alpha(s)$  is a *nonnegative integer (mesons)* or a *nonnegative integer plus 1/2 (baryons)*.

$$\alpha(s) \in N \text{ mesons}$$

$$\alpha(s) + 1/2 \in N \text{ baryons}$$

which gives some relation to our

$$\int_0^{\infty} x^s \varphi_{\sigma}(2x) \frac{dx}{x} = \frac{\cos \pi \nu}{\pi} \Gamma(s) B\left(\frac{1-s}{2}, \frac{s}{2}\right) B\left(\frac{s+\sigma}{2}, \frac{s-\sigma}{2}\right) .$$

#### 4. Huygens' Principle

In 1678 the great Dutch physicist Christian Huygens (1629-1695) wrote a treatise called *Traite de la Lumiere* on the wave theory of light, and in this work he stated that the wave front of a propagating wave of light at any instant conforms to the envelope of spherical wavelets emanating from every point on the wave front at the prior instant (with the



understanding that the wavelets have the same speed as the overall wave). An illustration of this idea, now known as Huygens' Principle, is shown below

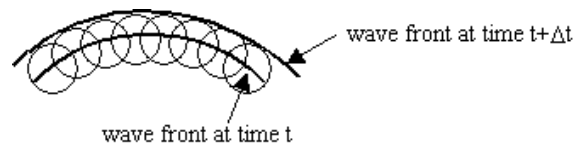

This drawing depicts the propagation of the wave "front", but Huygens' Principle is understood to apply equally to any locus of constant phase (not just the leading edge of the disturbance), all propagating at the same characteristic wave speed. This implies that a wave doesn't get "thicker" as it propagates, i.e., there is no diffusion of waves. For example, if we turn on a light bulb for one second, someone viewing the bulb from a mile away will see it "on" for precisely one second, and no longer. Similarly, the fact that we see sharp images of distant stars and galaxies is due to Huygens' Principle. However, it's worth noting that this principle is valid only in spaces with an odd number of dimensions. (See below for a detailed explanation of why this is so.) If we drop a pebble in a calm pond, a circular wave on the two-dimensional surface of the pond will emanate outward, and if Huygens' Principle was valid in two dimensions, we would expect the surface of the pond to be perfectly quiet both outside and inside the expanding spherical wave. But in fact the surface of the pond inside the expanding wave (in this two-dimensional space) is *not* perfectly calm, its state continues to differ slightly from its quiescent state even after the main wave has passed through. This excited state will persist indefinitely, although the magnitude rapidly becomes extremely small. The same occurs in a space with any even number of dimensions. Of course, the leading edge of a wave always propagates at the characteristic speed  $c$ , regardless of whether Huygens' Principle is true or not. In a sense, Huygens' Principle is more significant for what it says about what happens *behind* the leading edge of the disturbance. Essentially it just says that all the phases propagate at the same speed.

From this simple principle Huygens was able to derive the laws of reflection and refraction, but the principle is deficient in that it fails to account for the directionality of the wave propagation in time, i.e., it doesn't explain why the wave front at time  $t + \Delta t$  in the above figure is the upper rather than the lower envelope of the secondary wavelets. Why does an expanding spherical wave continue to expand outward from its source, rather than re-converging inward back toward the source? Also, the principle originally stated by Huygens does not account for diffraction. Subsequently, Augustin Fresnel (1788-1827) elaborated on Huygens' Principle by stating that the amplitude of the wave at any given point equals the superposition of the amplitudes of all the secondary wavelets at that point (with the understanding that the wavelets have the same frequency as the original wave). The Huygens-Fresnel Principle is adequate to account for a wide range of optical phenomena, and it was later shown by Gustav Kirchoff (1824-1887) how this principle can be deduced from Maxwell's equations. Nevertheless (and despite statements to the contrary in the literature), it does not actually resolve the question about "backward" propagation of waves, because Maxwell's equations themselves theoretically allow for advanced as well as retarded potentials. It's customary to simply discount the advanced waves as "unrealistic", and to treat the retarded wave as if it was the unique solution, although there have occasionally been interesting proposals, such as the Feynman-Wheeler theory, that make use of both solutions..

Incidentally, as an undergraduate, Feynman gave a seminar on this "new idea" at Princeton. Among the several "monster minds" (as Feynman called them) in attendance was Einstein, to whom the idea was not so new, because 30 years earlier Einstein had debated the significance of the advanced potentials with Walther Ritz. In any case, the Huygens-Fresnel Principle has been very useful and influential in the field of optics, although there is a wide range of opinion as to its scientific merit. Many people regard it as a truly inspired insight, and a fore-runner of modern quantum electro-dynamics, whereas others dismiss it as nothing more than a naive guess that sometimes happens to work. For example, in his excellent "Principles of Electrodynamics", Melvin Schwartz wrote:

*Huygens' principle tells us to consider each point on a wave front as a new source of radiation and add the "radiation" from all of the new "sources" together. Physically this makes no sense at all. Light does not emit light; only accelerating charges emit light. Thus we will begin by throwing out Huygens' principle completely; later we will see that it actually does give the right answer for the wrong reasons.*

Whether we have now actually found the true "reason" for the behavior of light is debatable, and ultimately every theory is based on some fundamental principle(s), but it's interesting how widely the opinions on various principles differ. (I'm reminded of the history of Fermat's Principle, and of Planck's reverence for the Principle of Least Action.) It could be argued that the "path integral" approach to quantum field theory – according to which every trajectory through every point in space is treated equivalently as part of a possible path of the system – is an expression of Huygens' Principle. It's also worth reflecting on the fact that the quantum concept of a photon necessitates Huygens' Principle, so evidently quantum mechanics can work only in space with an odd number of dimensions.

Setting aside these weighty considerations, it's interesting to review the mathematical content of Huygens' original principle. The usual wave equation for a scalar field  $\psi(x_1, x_2, \dots, x_n, t)$  in  $n$  space and 1 time dimension is

$$\frac{\partial^2 \psi}{\partial x_1^2} + \frac{\partial^2 \psi}{\partial x_2^2} + \dots + \frac{\partial^2 \psi}{\partial x_n^2} = \frac{\partial^2 \psi}{\partial t^2}$$

We've chosen units of time and space so that the wave velocity is 1.) If we consider a spherically symmetrical wave we have  $\psi = \psi(x, r)$  where  $r^2 = x_1^2 + x_2^2 + \dots + x_n^2$

For future reference, notice that

$$\frac{\partial r}{\partial x_j} = \frac{x_j}{r} \quad \text{and} \quad \frac{\partial^2 r}{\partial x_j^2} = \frac{r^2 - x_j^2}{r^3}$$

for every index  $j$  from 1 to  $n$ . It follows that

$$\sum_{j=1}^n \left(\frac{\partial r}{\partial x_j}\right)^2 = 1 \quad \text{and} \quad \sum_{j=1}^n \frac{\partial^2 r}{\partial x_j^2} = \frac{n-1}{r}$$

Returning to the basic wave equation, and assuming  $\psi$  is strictly a function of  $r$  and  $t$ , we have the following partial derivatives with respect to each of the space variables:

$$\frac{\partial \psi}{\partial x_j} = \frac{\partial \psi}{\partial r} \frac{\partial r}{\partial x_j} \quad \text{and} \quad \frac{\partial^2 \psi}{\partial x_j^2} = \frac{\partial \psi}{\partial r} \frac{\partial^2 r}{\partial x_j^2} + \frac{\partial r}{\partial x_j} \frac{\partial^2 \psi}{\partial x_j \partial r}$$

Since partial differentiation is commutative, the second factor in the last term of the right-hand equation can be written as

$$\frac{\partial^2 \psi}{\partial x_j \partial r} = \frac{\partial^2 \psi}{\partial r \partial x_j} = \frac{\partial}{\partial r} \left( \frac{\partial \psi}{\partial x_j} \right) = \frac{\partial}{\partial r} \left( \frac{\partial \psi}{\partial r} \frac{\partial r}{\partial x_j} \right) = \frac{\partial \psi}{\partial r} \frac{\partial^2 r}{\partial r \partial x_j} + \frac{\partial r}{\partial x_j} \frac{\partial^2 \psi}{\partial r^2}$$

Now, since

$$\frac{\partial^2 r}{\partial r \partial x_j} = \frac{\partial}{\partial x_j} \left( \frac{\partial r}{\partial r} \right) = 0$$

the preceding mixed partial is simply

$$\frac{\partial^2 \psi}{\partial r \partial x_j} = \frac{\partial r}{\partial x_j} \frac{\partial^2 \psi}{\partial r^2}$$

Substituting back into the expression for the second partial derivative of  $\psi$  with respect to  $x_j$ , we have

$$\frac{\partial^2 \psi}{\partial x_j^2} = \frac{\partial \psi}{\partial r} \frac{\partial^2 r}{\partial x_j^2} + \frac{\partial r}{\partial x_j} \frac{\partial r}{\partial x_j} \frac{\partial^2 \psi}{\partial r^2} = \frac{\partial \psi}{\partial r} \frac{\partial^2 r}{\partial x_j^2} + \left( \frac{\partial r}{\partial x_j} \right)^2 \frac{\partial^2 \psi}{\partial r^2}$$

Summing all these partials for  $j = 1$  to  $n$  gives

$$\sum_1^n \frac{\partial^2 \psi}{\partial x_j^2} = \frac{\partial \psi}{\partial r} \sum_1^n \frac{\partial^2 r}{\partial x_j^2} + \frac{\partial^2 \psi}{\partial r^2} \sum_1^n \left( \frac{\partial r}{\partial x_j} \right)^2 = \frac{n-1}{r} \frac{\partial \psi}{\partial r} + \frac{\partial^2 \psi}{\partial r^2}$$

Hence the spherically symmetrical wave equation in  $n$  spatial dimensions can be written as

$$\frac{\partial^2 \psi}{\partial t^2} = \frac{\partial^2 \psi}{\partial r^2} + \frac{n-1}{r} \frac{\partial \psi}{\partial r}$$

Now suppose we define a new scalar field by the relation  $\phi(r, t) = r^k \psi(r, t)$ , where  $k$  is some fixed constant. The partial derivative of this scalar field with respect to  $r$  are

$$\frac{\partial \phi}{\partial r} = r^k \frac{\partial \psi}{\partial r} + k r^{k-1} \psi \quad \text{and} \quad \frac{\partial^2 \phi}{\partial r^2} = r^k \frac{\partial^2 \psi}{\partial r^2} + 2k r^{k-1} \frac{\partial \psi}{\partial r} + k(k-1) r^{k-2} \psi$$

Notice that if we set  $k = (n-1)/2$ , and if we divide through this second partial by  $r^k$ , we have

$$\frac{1}{r^{(n-1)/2}} \frac{\partial^2 \phi}{\partial r^2} = \frac{\partial^2 \psi}{\partial r^2} + \frac{n-1}{r} \frac{\partial \psi}{\partial r} + \frac{(n-1)(n-3)}{4r^2} \psi$$

This is nearly the same as the left-hand side of the spherically symmetrical wave equation, except for the last term. Hence we can write the wave equation in the form

$$\frac{1}{r^{(n-1)/2}} \frac{\partial^2 \phi}{\partial r^2} - \frac{(n-1)(n-3)}{4r^2} \psi = \frac{\partial^2 \psi}{\partial t^2} .$$

Furthermore, we can multiply through by  $r^k = r^{(n-1)/2}$  to put this in the equivalent form

$$\frac{\partial^2 \phi}{\partial r^2} - \frac{(n-1)(n-3)}{4r^2} \phi = \frac{\partial^2 \phi}{\partial t^2}$$

If  $n$  equals 1, meaning that we have just a single space dimension, then  $r = x_1$  and  $\phi = \psi$ , so we expect the second term on the left hand side to vanish identically, as indeed it does, leaving us with just the original one-dimensional wave equation, with the well-known general solution

$$\psi(r, t) = f(r-t) + g(r+t)$$

for arbitrary functions  $f$  and  $g$ . However, we might not have anticipated that the second term in the transformed wave equation also vanishes if  $n$  equals 3, i.e., in the case of three spatial dimensions. In this case the spherically symmetrical wave equation once again reduces to a one-dimensional wave equation, although in the modified wave function  $\phi = r\psi$ . Hence the general solution in three space dimensions is

$$\psi(r, t) = \frac{f(r-t)}{r} + \frac{g(r+t)}{r}$$

The fact that this solution is divided by  $r$  signifies that the magnitude of the wave tends to drop as  $r$  increases (unlike the one-dimensional case, in which a wave would theoretically propagate forever with undiminished strength). Focusing on just the "retarded" component of the wave,  $\frac{f(r-t)}{r}$ , the fact that the time parameter  $t$  appears only in the difference  $r-t$  implies that the (attenuated) wave propagates in time with a phase velocity of precisely 1, because for any fixed phase  $\beta$  we have  $r-t = \beta$  and so  $\frac{dr}{dt}$  for this phase point is 1.

Consequently if  $f$  is a single pulse, it will propagate outward in a spherical shell at precisely the speed 1, i.e., on the light cone. Conversely, it can be shown that the wave function at any point in space and time is fully determined by the values and derivatives of that function on the past light cone of the point. Any wave equation for which this is true (i.e., for which disturbances propagate at a single precise speed) is said to satisfy Huygens' Principle. The connection with Huygens' original statement about secondary wavelets is that each wavelet - with the same speed as the original wave - represents a tiny light cone at that point, and Huygens' principle asserts that light is confined to those light cones.

It's worth noting that in the above derivation we were able to reduce the polar wave equation to a simple one-dimensional equation by taking advantage of the fact that an unwanted term vanished when the number of space dimensions is  $n=3$  (or  $n=1$ ). For the case of two dimensional space this doesn't work (nor would it work with four space dimensions). We can still solve the wave equation, but the solution is not just a simple spherical wave propagating with unit velocity. Instead, we find that there are effectively infinitely many velocities, in the sense that a single pulse disturbance at the origin will propagate outward on infinitely many "light cones" (and sub-cones) with speeds ranging from the maximum down to zero. Hence if we lived in a universe with two spatial dimensions (instead of three), an observer at a fixed location from the origin of a single pulse would "see" an initial flash but then the disturbance

"afterglow" would persist, becoming less and less intense, but continuing forever, as slower and slower subsidiary branches arrive.

It's interesting to compare and contrast this "afterglow" with the cosmic microwave background radiation that we actually do observe in our 3+1 dimensional universe. Could this glow be interpreted as evidence of an additional, perhaps compactified, spatial dimension? What would be the spectrum of the glow in a non-Huygensian universe? Does curvature of the spatial manifold affect Huygens' principle?

It turns out that Huygens' Principle applies only with one time dimension and  $n = 3, 5, 7, \dots$ , or any odd number of space dimensions, but not for any even number of space dimensions. (The case  $n = 1$  is degenerate, because a pulse has only one path to take.) To see why, let's return to the general spherically symmetrical wave equation in  $n$  space dimensions

$$\frac{\partial^2 \psi}{\partial r^2} + \frac{(n-1)}{r} \frac{\partial \psi}{\partial r} = \frac{1}{c^2} \frac{\partial^2 \psi}{\partial t^2}$$

and consider a solution of the form  $\psi(r, t) = f(r)g(t)$ . (Naturally not all solutions are separable in this way, but since the wave equation is linear, we can construct more general solutions by summing a sufficient number of solutions of the separable form  $f(r)g(t)$ .)

Inserting this into the wave equation and expanding the derivatives by the product rule gives

$$g \frac{d^2 f}{dr^2} + g \frac{(n-1)}{r} \frac{df}{dr} = f \frac{1}{c^2} \frac{d^2 g}{dt^2}$$

Dividing through by  $fg$  gives

$$\frac{1}{f} \frac{d^2 f}{dr^2} + \frac{1}{f} \frac{(n-1)}{r} \frac{df}{dr} = \frac{1}{gc^2} \frac{d^2 g}{dt^2}$$

Notice that the left hand side is strictly a function of  $r$ , and the right hand side is strictly a function of  $t$ . Since  $r$  and  $t$  are independent variables, the left and right sides must both equal a constant, which we will denote by  $\kappa$ . Hence we have two separate ordinary differential equations

$$\frac{1}{f} \frac{d^2 f}{dr^2} + \frac{1}{f} \frac{(n-1)}{r} \frac{df}{dr} = \kappa \quad \frac{1}{gc^2} \frac{d^2 g}{dt^2} = \kappa$$

If  $\kappa$  is positive or zero the right hand equation gives "run-away" solutions for  $g(t)$ , whereas if  $\kappa$  is negative we can choose scaling so that  $\kappa = -1$  and then  $g(t)$  satisfies the simple harmonic equation, whose solutions include functions of the form  $\sin(ct)$  and  $\cos(ct)$ . The left hand equation can be re-written in the form

$$r \frac{d^2 f}{dr^2} + (n-1) \frac{df}{dr} + rf = 0$$

If we multiplied this through by  $r$ , it would be in the form of what is called Bessel's equation, named after Friedrich Wilhelm Bessel (1784-1846), the German astronomer who (incidentally) was the first person to determine the distance to a star (other than the Sun). In 1838 he determined the distance to the star called "61 Cygni" based on the parallax as

viewed from the Earth at six-month intervals. Bessel functions are solutions of a standard Bessel equation, just as the ordinary trigonometric functions, sine and cosine, are solutions of the differential equation  $y'' + y = 0$ .

To solve the above equation we can assume a series solution of the form

$$f(r) = c_0 r^q + c_1 r^{q+1} + c_2 r^{q+2} + \dots$$

for some integer  $q$  (which may be positive, negative, or zero) such that  $c_0$  is non-zero. The derivatives of this function are

$$\frac{df}{dr} = qc_0 r^{q-1} + (q+1)c_1 r^q + (q+2)c_2 r^{q+1} + \dots$$

$$\frac{d^2 f}{dr^2} = q(q-1)c_0 r^{q-2} + (q+1)qc_1 r^{q-1} + (q+2)(q+1)c_2 r^q + \dots$$

Substituting these into the differential equation, and collecting terms by powers of  $r$ , we get

$$0 = c_0 [q(q-1) + (n-1)q] r^{q-1} + c_1 [(q+1)q + (n-1)(q+1)] r^q + \{[(q+2)(q+1) + (n-1)(q+2)]c_2 + c_0\} r^{q+1} + \\ + \{[(q+3)(q+2) + (n-1)(q+3)]c_3 + c_1\} r^{q+2} + \dots$$

The coefficient of each power of  $r$  must vanish, and since  $c_0$  is non-zero, the expression for the first coefficient implies  $q(q-2+n) = 0$ . This is called the indicial equation, because it determines the acceptable value(s) of  $q$ . In this case we must have either  $q = 0$  or else  $q = 2 - n$ . If  $q = 0$  then the coefficient of  $r^q$  equals  $c_1(n-1)$ , so either  $n = 1$  or else  $c_1 = 0$ . On the other hand, if  $q = 2 - n$ , then the coefficient of  $r^q$  equals  $c_1(3-n)$ , so either  $n = 3$  or else again  $c_1 = 0$ . We've already seen that the original differential equation has a particularly simple analytical solution when  $n$  (the number of space dimensions) equals either 1 or 3, so we need not consider them here. For all other value of  $n$ , we must have  $c_1 = 0$ . (Of course, even with  $n = 1$  or  $n = 3$ , we are free to set  $c_1 = 0$ .)

Now, examining the coefficients of the higher powers of  $r$ , we see that in general the coefficient of  $r^{q+m}$  is of the form

$$\{[(q+m+1)(q+m) + (n-1)(q+m+1)]c_{m+1} + c_{m-1}\}$$

Inserting  $q = 0$ , setting the overall coefficient to zero, and solving for  $c_{m+1}$  gives

$$c_{m+1} = \frac{-c_{m-1}}{(m+1)(m+n-1)}$$

for  $m = 0, 1, 2, 3, \dots$ . Since  $c_0$  is, by definition, the first non-zero coefficient, it follows that  $c_{-1}$  is zero, and therefore  $c_1 = 0$ . Moreover, applying the above formula recursively, we see that all

the  $c_j$  coefficients for odd indices  $j$  must vanish. On the other hand, the coefficients with even indices are given recursively by

$$c_2 = c_0 \frac{-1}{2n}, \quad c_4 = c_2 \frac{-1}{4(n+2)}, \quad c_6 = c_4 \frac{-1}{6(n+4)}$$

and so on. Notice that if  $n = 1$  the denominators are  $1*2, 3*4, 5*6, \dots$ , etc., so the general non-zero coefficient of the solution can be written simply as

$$c_{2j} = c_0 \frac{(-1)^j}{(2j)!}$$

giving the solution

$$f(r) = c_0 \left( 1 - \frac{1}{2!} r^2 + \frac{1}{4!} r^4 - \dots \right)$$

Hence the solution is simply  $f(r) = c_0 \cos(t)$ . Recall that  $g(t)$  has solutions of the form  $\cos(ct)$  and  $\sin(ct)$ , and we can create a solution given by the sum of two separable solutions, so, for example, one solution is

$$\psi(r, t) = f_1(r)g_1(ct) + f_2(r)g_2(ct) = \cos(r)\cos(ct) + \sin(r)\sin(ct) = \cos(r - ct)$$

Similarly if  $n = 3$  the denominators of the recursive formulas are  $2*3, 4*5, 6*7, \dots$  etc., so the general non-zero coefficient is

$$c_{2j} = c_0 \frac{(-1)^j}{(2j+1)!}$$

giving the solution

$$f(r) = \frac{c_0}{r} \left( r - \frac{1}{3!} r^3 + \frac{1}{5!} r^5 - \dots \right)$$

so in this case we have  $f(r) = c_0 \sin(t)/r$ . Combining this with suitable solutions for  $g(t)$  as in the case of  $n = 1$ , we can arrive at overall solutions such as  $\psi(r, t) = \cos(r - ct)/r$ . This shows (again) that the cases of 1 and 3 spatial dimensions lead to especially simple solutions.

In general, for arbitrary positive integer  $n$ , the coefficient  $c_{2j}$  is of the form

$$c_{2j} = c_0 \frac{(-1)^j}{(2)(4)(6)\dots(2j) [(n)(n+2)\dots(n+2(j-1))]}$$

Notice that for  $n = 1$  the factors in the square brackets are consecutive odd integers, and they can be interleaved between the consecutive even integers to give a pure factorial product. Likewise for  $n = 3$  the odd and even factors can be interleaved to give a pure factorial product. For higher odd integers we can interleave the factors in the same way, although there will be a fixed number of leading even factors and the same number of trailing

odd factors that don't overlap. For example, with  $n = 7$  the coefficient  $c_{12}$  is as shown below, after re-arranging the six even and six odd factors in the denominator

$$c_{12} = c_0 \frac{(-1)^6}{(2)(4)[(6)(7).8)(9)(10)(11)(12)(13)](15)(17)}$$

Taking advantage of this interleaving, we can express the general coefficient (for sufficiently large  $j$ ) with odd  $n > 3$  in the form

$$c_{2j} = \frac{c_0 (n-1)!}{2^{(n-3)/2} \left(\frac{n-3}{2}\right)!} \frac{1}{(2j+3)(2j+5)\dots(2j+n-2)} \frac{(-1)^j}{(2j+1)!}$$

For any fixed  $n$ , the first factor on the right is just a constant, and the second factor is just one over a polynomial of degree  $(n-3)/2$  in the index  $j$ . Therefore, after some number of terms, the series solution goes over to a simple factorial form with a polynomial divisor. It can be shown that the resulting function  $f(r)$  is such that Huygens' Principle is satisfied, so this implies that the principle is satisfied for any odd number of space dimensions. This gives a relation to spherical waves in higher dimensions.

In contrast, if the number of space dimensions is even, we do not have interleaving of the factors in the denominator of the coefficients. In this case we can only re-write (1) in the form

$$c_{2j} = \frac{c_0 \left(\frac{n}{2} - 1\right)!}{2^{2j} j! \left(\frac{n}{2} - 1 + j\right)!} (-1)^j$$

For example, in the case  $n = 2$  (i.e., two spatial dimensions) we have the coefficients

$$c_{2j} = \frac{c_0 \left(-\frac{1}{4}\right)^j}{(j!)^2}$$

This gives the function

$$f(r) = c_0 \left(1 - \frac{1}{(1!)^2} \left(\frac{r^2}{4}\right)^2 + \frac{1}{(2!)^2} \left(\frac{r^2}{4}\right)^2 - \frac{1}{(3!)^2} \left(\frac{r^2}{4}\right)^2 \dots\right)$$

This is the Bessel function of order zero, often denoted as  $J_0$ . A plot of this function is shown below.



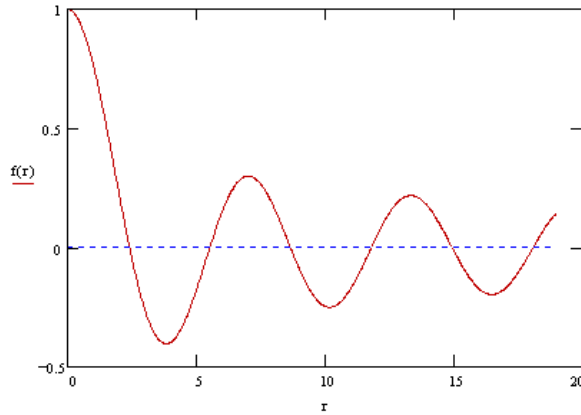

For positive arguments  $r$ , the Bessel function  $J_0(r)$  can be expressed as

$$J_0(r) = \frac{2}{\pi} \int_0^{\infty} \sin(\cosh(\mathcal{G}r)) d\mathcal{G}$$

Multiplying through by the temporal solution  $g(t) = \sin(ct)$  gives

$$\psi(r, t) = \frac{1}{\pi} \int_0^{\infty} [\cos(\cosh(\mathcal{G}r - ct)) - \cos(\cosh \mathcal{G}r + ct)] d\mathcal{G}$$

Hence, instead of the solution being purely a function of  $r \pm ct$  as in the case of odd dimensions, we find that it is an integral of functions of  $\cosh \mathcal{G}r \pm ct$ . Each value of  $\mathcal{G}$  corresponds to a propagation speed of  $c/\cosh \mathcal{G}$ , so the speeds vary from  $c$  down to zero. This signifies that the wave function at any event is correlated not just with the wave function on its "light cone", but with the wave function at every event inside its light cone. (However, as discussed in another note, we must be cautious about inferring causality relations from such formulas.)

It would be interesting to work out the connections between Huygens' Principle and the zeta function (whose value can only be given in simple closed form for even arguments) and the Bernoulli numbers (which are non-zero only for even indices). It's also interesting to note the analogy between Huygens' spherical wavelets centered on the boundary of the wave front and the technique of analytic continuation, by which we expand the boundary of an analytic region by means of disks of convergence centered on or near the boundary of the existing analytic region.

Paul Dirac (1902-1984) gave an interesting general argument for a much stronger version of Huygens' Principle in the context of quantum mechanics. In his "Principles of Quantum Mechanics" he noted that a measurement of a component of the instantaneous velocity of a free electron must give the value  $\pm c$ , which implies that electrons (and massive particles in general) always propagate along null intervals, i.e., on the local light cone. At first this may seem to contradict the fact that we observe massive objects to move at speeds much less than the speed of light, but Dirac points out that observed velocities are always average velocities over appreciable time intervals, whereas the equations of motion of the particle show that its velocity oscillates between  $+c$  and  $-c$  in such a way that the mean value agrees with the average value. He argues that this must be the case in any relativistic theory

that incorporates the uncertainty principle, because in order to measure the velocity of a particle we must measure its position at two different times, and then divide the change in position by the elapsed time. To approximate as closely as possible to the instantaneous velocity, the time interval must go to zero, which implies that the position measurements must approach infinite precision. However, according to the uncertainty principle, the extreme precision of the position measurement implies an approach to infinite indeterminacy in the momentum, which means that almost all values of momentum - from zero to infinity - become equally probable. Hence the momentum is almost certainly infinite, which corresponds to a speed of  $\pm c$ . This is obviously a very general argument, and applies to all massive particles (not just fermions).

## 5. Spherical Waves and the Telegraph Equation

The propagation of the spherical electromagnetic (or sound) wave has been given in a system  $\mathcal{K}$  by the following equation

$$x^2 + y^2 + z^2 - c^2 t^2 = 0$$

The „vibration string“ equation with a solution in the form  $u(x,t) = f(x^2 - kt^2)$ ,  $f(0) = 1$  for any function of one variable  $f$  has the form

$$u_{tt} - k^2 u_{xx} = \lambda^2 u$$

For the telegraph equation

$$L[u] := u_{xy} + cu = g(x,y)$$

the corresponding Riemann function is given by

$$v(x, y; \xi, \eta) = J_0 4 \sqrt{c(x - \xi)(y - \eta)} .$$

## 6. Wellenausbreitung in drei Dimensionen

Wir betrachten zuerst den Fall 3-dimensionaler Wellenausbreitung, da die 2D-Greenfunktion im Zeitbereich leicht aus der 3D-Greenfunktion abgeleitet werden kann. Im 3D-Fall lautet die Wellengleichung

$$G_{tt}(\vec{x}, t) - \alpha^2 \Delta G(\vec{x}, t) = \frac{F(\vec{x}, t)}{\rho}$$

Wir betrachten einen Vollraum mit einer Punktquelle im Ursprung. Zur Darstellung der Punktquelle benötigen wir eine Definition der Deltafunktion in drei Dimensionen. Die Selektionseigenschaft der Deltafunktion soll nun lauten

$$\int_V h(\vec{r}) \delta(\vec{r} - \vec{r}_0) dV = h(\vec{r}_0)$$

Wir suchen wieder die Greensche Funktion, d. h. die Lösung der Gleichung

$$\frac{\partial^2 G(\vec{r}, t)}{\partial t^2} - \alpha^2 \Delta G = \frac{1}{\rho} q(t) \delta(\vec{r})$$

mit  $q(t < 0) = 0$  und den Anfangsbedingungen  $G(\vec{r}, \vec{r}_0, 0) = \dot{G}(\vec{r}, \vec{r}_0, 0) = 0$ . Um wieder eine alternative Formulierung des Problems zu finden, wird über eine Kugel mit Radius  $\varepsilon$  integriert. Dabei kommt uns zugute, daß  $\Delta G = \nabla(\nabla G)$ , und der Gaußsche Satz angewendet werden kann. Unter der Voraussetzung, daß das Volumenintegral über  $\frac{\partial^2 G(\vec{r}, t)}{\partial t^2}$  verschwindet, erhält man

$$0 = \int_{S(\varepsilon)} (\nabla G) \vec{n} dS + \frac{1}{\rho} q(t)$$

Die alternative Problemstellung ist demnach:

$$\frac{\partial^2 G(\vec{r}, t)}{\partial t^2} - \alpha^2 \Delta G = 0 \quad |\vec{r}| > 0$$

$$\lim_{\varepsilon \rightarrow 0} \int_{S(\varepsilon)} (\nabla G) \vec{n} dS = -\frac{1}{\rho} q(t)$$

Wir haben es jetzt nicht wie im 1D-Fall mit einer Unstetigkeit der Ableitung der Greenschen Funktion zu tun, sondern mit einer Singularität der Greensche Funktion im Ursprung, die so geartet ist, daß obiges Oberflächenintegral einen endlichen Wert hat.

Da die Welle sich kugelförmig vom Herd ausbreitet, hängt die Greensche Funktion nur vom Abstand von der Quelle ab. Man arbeitet daher am besten in Kugelkoordinaten. Der Laplace-Operator lautet in Kugelkoordinaten

$$\nabla^2 = \frac{1}{r^2} \frac{\partial}{\partial r} \left( r^2 \frac{\partial}{\partial r} \right) + \frac{1}{r^2 \sin \theta} \frac{\partial}{\partial \theta} \left( \sin \theta \frac{\partial}{\partial \theta} \right) + \frac{1}{r^2 \sin^2 \theta} \frac{\partial^2}{\partial \phi^2}$$

sodaß unser Problem nun lautet:

$$\frac{\partial^2 G(r,t)}{\partial t^2} = \alpha^2 \frac{1}{r^2} \frac{\partial}{\partial r} \left( r^2 \frac{\partial G(r,t)}{\partial r} \right) \quad r > 0$$

$$\lim(4\pi r^2 \frac{\partial G}{\partial r}) = -\frac{1}{\rho\alpha^2} q(t)$$

Mit der neuen Variable  $\Gamma = rG$  erhält man daraus für  $r > 0$  die 1D-Wellengleichung

$$\frac{\partial^2 \Gamma(r,t)}{\partial t^2} = \alpha^2 \frac{\partial^2 \Gamma(r,t)}{\partial r^2}$$

und die Bedingung

$$\lim(r \frac{\partial \Gamma(r,t)}{\partial r} - \Gamma(r,t)) = -\frac{q(t)}{4\pi\rho\alpha^2}$$

Das dreidimensionale Problem ist auf ein eindimensionales reduziert worden. Allerdings sieht die Zusatzbedingung an der Quelle völlig anders aus als im 1D-Fall. Wir werden deshalb auch eine völlig andere Lösung bekommen.

Da die Quelle im Ursprung liegt, kommen nur auslaufende Wellen in Frage. Wir machen den Ansatz

$$\Gamma(r,t) = f(r - \alpha t)$$

Die Zusatzbedingung liefert

$$\lim(r f'(r - \alpha t) - f(r - \alpha t)) = -\frac{q(t)}{4\pi\rho\alpha^2} \quad r \rightarrow 0$$

woraus folgt

$$f(-\alpha t) = \frac{q(t)}{4\pi\rho\alpha^2} \quad \text{oder} \quad f(x) = \frac{q(-x/\alpha)}{4\pi\rho\alpha^2}$$

Die Greensche Funktion lautet demgemäß ganz einfach

$$G(r,t) = \frac{1}{r} \frac{q(t)}{4\pi\rho\alpha^2} q(t - \frac{r}{\alpha})$$

Erstaunlicherweise erhält man die einfachste Lösung im 3D-Fall. Das Signal ist identisch mit der Quellfunktion, während es im 1D-Fall eine integrierte Version des Quellsignals war. Die Kausalität ist offensichtlich, da für  $r > \alpha t$  das Argument von  $q$  negativ ist und somit  $q = 0$ . Eine Besonderheit ist der Amplitudenabfall mit  $r^{-1}$ . Man nennt diesen Faktor auch das geometrische Spreading. Geht man davon aus, daß der Energiefluß durch eine Kugelschale proportional zum Quadrat der Amplitude ist, so folgert man aus der Energieerhaltung

$$4\pi\rho\alpha^2 G^2(r,t) = \text{constant}$$

woraus folgt, daß  $G$  mit  $r-1$  abfallen muß.

Interessant ist, daß im 3D-Fall die Impulsantwort keine Sprungfunktion sondern eine Deltafunktion ist;

$$h(r,\tau) = \frac{1}{r} \frac{1}{4\pi\rho\alpha^2} \delta\left(\tau - \frac{r}{\alpha}\right)$$

Das heißt, ein Impuls, der bei  $\tau = 0$  abgeschickt wird, kommt zurzeit  $\tau = \frac{r}{\alpha}$  *unverändert* am Empfänger an.

Die Greensche Funktion im Frequenzbereich erhalten wir einfach durch Fouriertransformation der Greensche Funktion im Zeitbereich

$$\hat{G}(r,\omega) = \frac{1}{r} \frac{1}{4\pi\rho\alpha^2} \int_{-\infty}^{\infty} q\left(t - \frac{r}{\alpha}\right) e^{-i\omega t} dt = \frac{1}{r} \frac{1}{4\pi\rho\alpha^2} \int_{-\infty}^{\infty} q(t) e^{-i\omega\left(t + \frac{r}{\alpha}\right)} dt = \frac{1}{r} \frac{1}{4\pi\rho\alpha^2} q(\omega) e^{-i\omega r/\alpha}$$

man sich den Zeitfaktor  $e^{-i\omega t}$  hinzu, sieht man, daß wir es wie erwartet mit einer auslaufenden, harmonischen Kugelwelle zu tun haben.

Sphärische Wellen (Kugelwellen) sind Lösungen der Gleichung

$$\frac{\partial^2(rE)}{\partial t^2} = c^2 \frac{\partial^2(rE)}{\partial r^2}$$

Mittel dem Ansatz  $rE = f(r \pm ct)$  ergibt sich

$$E(r,t) = E_0 \frac{1}{r} e^{-i(kr \pm \omega t)} .$$

Zylinderwellen sind Lösungen der Gleichung

$$\frac{\partial^2 E}{\partial t^2} = c^2 \frac{1}{r} \frac{\partial}{\partial r} \left( r \frac{\partial E}{\partial r} \right)$$

Es ergibt sich

$$E(r,t) = \pi H_0(kr,t) \text{ mit } H_0(kr,t) = \sqrt{\frac{2}{\pi r}} e^{-i(kr \pm \omega t + \pi/4)} .$$

The Helmholtz equation with space dimension  $n$  is given by

$$\nabla u + \lambda^2 u = \begin{cases} -\Delta_i & \text{in } \Omega \\ 0 & \text{elsewhere} \end{cases}$$

where  $\Delta_i$  represents the Dirac delta function at the source point  $i$  corresponding to the fundamental solution. The domain  $\Omega$  can be unbounded or bounded with or without boundary conditions;  $x$  denotes the  $n$ -dimensional coordinate variable and  $r_k := \|x - x_k\|$

The kernel wavelet basis functions are

$$h_n(\lambda r_k) := -\frac{i\lambda^{n-1/2}}{4} (2\pi\lambda r_k)^{1-n/2} H_{n/2-1}^{(2)}(\lambda r_k) \quad , \quad n \geq 2$$

where  $\bar{h}_n$  comply with the divergence (conservation) theorem

$$\lim_{r_k \rightarrow 0} r_k^{n-1} S_n(1) \frac{\partial g_n}{\partial r_k} = -1 \quad , \quad r_k \rightarrow 0$$

and  $h_n$  satisfy the Sommerfeld radiation condition at infinity

$$\lim_{r \rightarrow \infty} r \left[ \frac{\partial g_n}{\partial r_k} + i\lambda g_n \right] = 0 \quad , \quad r_k \rightarrow \infty$$

The link to the density function (2.1) below is given by

$$r \left| H_{n/2-1}^{(1)}(r) \right|^2 = r H_{n/2-1}^{(1)}(r) H_{n/2-1}^{(2)}(r) = r \left[ \frac{J_{\frac{n-2}{2}}^2(r) + Y_{\frac{n-2}{2}}^2(r)}{2} \right]$$

With reference to fractional mathematics we note that  $\nu := \frac{1}{4}$  in (2.1) would correspond to a fractional dimension of space of  $n = 2.5$ .

Using the Hankel functions

$$H_\nu^{(1)}(x) := J_\nu(x) + iY_\nu(x) \quad \text{resp.} \quad H_\nu^{(2)}(x) := J_\nu(x) - iY_\nu(x)$$

and

$$R_\nu^2(x) := \left[ J_\nu^2(x) + Y_\nu^2(x) \right] = H_\nu^{(1)}(x) \overline{H_\nu^{(2)}(x)} = \left| H_\nu^{(1)}(x) \right|^2$$

it follows

$$H_\nu^{(1)}(x) = R_\nu(x) e^{i\Psi_\nu} \quad \text{resp.} \quad H_\nu^{(2)}(x) = R_\nu(x) e^{-i\Psi_\nu} .$$

Putting  $\Psi(x) := \Psi_{\frac{1}{4}}(x)$  ..... can be re-formulated to

$$\frac{\pi}{2} R_\nu^2(x) d\Psi_\nu = \frac{dx}{x} \quad \text{resp.} \quad \frac{N(2x)}{8x} d\Psi = \frac{2}{\pi} \left| K_{\frac{1}{4}}(\pm ix) \right|^2 d\Psi = \frac{dx}{x}$$

With reference to Hankel functions we mention

$$H_\nu^{(1)}(r) = J_\nu(r) + iY_\nu(r) = \sqrt{J_\nu^2(r) + Y_\nu^2(r)} e^{i\Psi_\nu(r)}$$

resp. 
$$H_\nu^{(1)}(r) = N(2r) \frac{e^{i\Psi_\nu(r)}}{4\pi} = \frac{2}{\pi} \frac{e^{i\Psi_\nu(r)}}{\Psi'_\nu(r)} = \frac{2}{\pi} \frac{e^{i\Psi_\nu(r)}}{1-\psi'(r)} \quad \text{with } \nu := \frac{1}{4}$$

which might motivate an alternative or additional “polar” coordinate transformation in the context of Riemann manifolds.

### 7. Spherical waves, Cauchy and radiation problem, Huygens principle in space dimension $m=3$

This section is referring to Courant-Hilbert, Methods of mathematical physics II, chapter VI, §5.6, §10.3. being  $m$  die space dimension and  $n = m + 1$ .



Huygens principle is valid for odd  $m$  under the same condition as both, Cauchy's initial value problem and the radiation problem, which we recall in the following, whereby we restrict to  $m = 3$ :

Being  $B_\varepsilon^3 = \{(x, y, z) \in R^3 \mid x^2 + y^2 + z^2 = \varepsilon\}$  the ball with center 0 and radius  $\varepsilon$  and

$\frac{\partial}{\partial \vec{n}} = \langle \text{gradu}, \vec{n} \rangle = \frac{\partial}{\partial \vec{r}}$  the differentiation in the direction of the external normal. With the abbreviation

$$\otimes u := \lim \int \int_{B_\varepsilon^3} \frac{\partial u}{\partial \vec{n}} dO$$

$$u_{tt} - \Delta u = 0 \quad \text{for } t > 0$$

$$u(x, y, z, 0) = 0$$

$$u_t(x, y, z, 0) = 0$$

$$\otimes u = -g(t) ,$$

being  $g(t)$  the intensity of the radiation.

The solution of this radiation problem is spherical waves of order  $\frac{n-1}{2}$  with the wave form

$$W(t) = \frac{g(t)}{\omega_m(m-2)} ,$$

i.e.  $u(r, t) = \frac{g(t-r)}{4\pi r}$  for  $m = 3$

$$u(r, t) = \frac{r^{2-m}}{(4\pi)^{(m-1)/2}} \sum_0^{(m-3)/2} \frac{(m-3-i)!}{i!((m-3)/2-i)!} g^{(i)}(t-r) \quad \text{for } m \geq 3, m \text{ odd.}$$

There is an unproven hypothesis in the following sense:

**Spherical wave are characterized by both, for any time like lines only existing for  $n = m+1 = 2$  or  $n = m+1 = 4$  and only for wave equation like differential equations.**

### 8. Fourier analysis for the wave equation

The solution of the distribution equation

$$S_{tt}(t, x) - \Delta S(t, x) = \delta(t)\delta^m(x)$$

is called Green's function (or propagator in physics). Using the Fourier transform

$$\hat{S}(\omega, k) = \iint S(t, x) e^{i\omega t - ikx} dx dt$$

$$S(t, x) = \frac{1}{2\pi} \iint \frac{1}{(2\pi)^m} \hat{S}(\omega, k) e^{-i\omega t + ikx} dx dt$$

leads to an algebraic equation in the form

$$(\omega^2 - |k|^2) \hat{S}(\omega, k) = 1 .$$

These results into

$$(*) \quad S(t, x) = \frac{1}{2\pi} \iint \frac{1}{(2\pi)^m} \frac{1}{(\omega^2 - |k|^2)} e^{-i\omega t + ikx} dx dt$$

which first requires an analysis of the integral for fixed k?

$$\int_{-\infty}^{\infty} \frac{e^{-i\omega t}}{(\omega^2 - |k|^2)} d\omega .$$

In den Fällen  $t > 0$  und  $t < 0$  fällt der Integrand exponentiell ab falls  $\text{Im}(\omega) > 0$  nach  $-\infty$  bzw.  $\infty$  strebt. Man kann das  $\omega$ -Integral in der unteren bzw. in der oberen komplexen Halbebene schliessen. Damit erhält man ein geschlossenes Konturintegral, das mit Hilfe des Residuensatzes gelöst werden kann. Allerdings sind die Pole des Integranden reell und liegen damit genau auf dem Kontur, d.h. folgendes: wählt man unterschiedliche Pole um die Pole herum, so ändert sich der Wert des Integrals um ein Vielfaches der Residuen bei  $\omega = \pm |k|$ . Damit wird das Integral (\*) um einen Beitrag

$$c_1 e^{-i|k|t + ikx} + c_2 e^{i|k|t + ikx}$$

mit komplexen Koeffizienten  $c_{1/2}$  abgeändert, which are plane waves and solutions- of the homogeneous wave equation, heisst sie fallen heraus aus der obigen Distributionsgleichung. This means that the Green function is not unique. To get specific solutions one chooses specific contours around the poles. The technique doing is, is to shift the pole by an  $\varepsilon$  and let get  $\varepsilon \rightarrow 0$ . The way how making this infinite shift determines different Green functions. The Green functions of special interest are avancierte bzw. Retardierte Green'sche Funktionen, i.e.

$$\tilde{S}(t, x) = \lim \frac{1}{2\pi} \iint \frac{1}{(2\pi)^m} \frac{1}{(\omega - |k| - i\varepsilon)(\omega + |k| - i\varepsilon)} e^{-i\omega t + ikx} dx dt$$

$$\tilde{S}(t, x) = \frac{i}{2} \theta(-t) \int \frac{1}{(2\pi)^m} \frac{1}{|k|} (e^{-i|k|t + ikx} - e^{i|k|t + ikx}) dx dt$$

resp.

$$\widehat{S}(t, x) = \lim \frac{1}{2\pi} \iint \frac{1}{(2\pi)^m} \frac{1}{(\omega - |k| + i\varepsilon)(\omega + |k| + i\varepsilon)} e^{-i\omega t + ikx} dx dt$$

$$\widehat{S}(t, x) = -\frac{i}{2} \theta(t) \int \frac{1}{(2\pi)^m} \frac{1}{|k|} (e^{-i|k|t + ikx} - e^{i|k|t + ikx}) dx dt,$$

whereby  $\theta(t)$  is the Heaviside function, i.e.

$$\theta(t) = \begin{cases} 1 & \text{for } t \geq 0 \\ 0 & \text{for } t < 0 \end{cases}.$$

## 9. Magical Lagrange and Hamilton analytical mechanics

Lagrange vs. Hamiltonian formalism are two sides of the same coin, same underlying calculus concept to handle infinitesimal actual (!) “distances”  $dx$  to model momentum and

action. Impressed forces are accepted, but within the variation concept ..... heben sich gegenseitig auf bzw. erzeugen keine Wirkung --> ignored.

In Leibniz's philosophy the "force" (impressed force only?) is equivalent to an "active substance"="monad", which is at the same time a "substance" in Plato's ideal world, with no extension, i.e. an "existing point in space" (Penrose 3.3), where from a physical point of view, there is no evidence for its existence. Point particles, path integrals, gauges theory, Leibniz assumes that the whole of mathematics is found inside us.

In the one-dimensional case the concept of hyperfunctions enables a link between distributions and a holomorphic, i.e. a complex-analytical function, as any distribution  $f$  on  $R$  can be realized as the "jump" of the corresponding in  $C - R$  holomorphic Cauchy integral function

$$\hat{f}(x) := F(x) := \frac{1}{2\pi i} \oint \frac{f(t)dt}{t-x}$$

across the real axis, given by

$$(f, \varphi) = \lim_{y \rightarrow 0^+} \int_{-\infty}^{\infty} (F(x+iy) - F(x-iy))\varphi(x)dx \quad \text{for } y \rightarrow 0^+ .$$

The Hilbert transform  $H$  gives a Cauchy principle-valued function with Fourier terms

$$(Hu)_\nu = -i \operatorname{sgn}(\nu)u_\nu .$$

The study of the Hilbert transform and the study of operational calculus for non-commuting operators in quantum mechanics (e.g. the Weyl operator) contain some of the basic ingredients of the theory of pseudo differential operators ([BPe] B. E. Petersen, 3.1). Freeding the Hilbert transform from its too intimate link connection with complex variables techniques Calderon and Zygmund introduced the algebra of singular integral operators (modulo compact operators) based on salient features of the Hilbert transform ([BPe] B. E. Petersen, 2.9). This also stimulated the study of the algebra generated by singular differential operators and partial differential operators ([BPe] B. E. Petersen, 4.1ff), which all leads into the concept of pseudo differential operator.

The Hilbert transform, which is a classical Pseudo differential operator, transforms the Gauss-Weierstrass density function into a "P.v. distribution" ([24] B. E. Petersen, 1.7, ) in the form

$$(*) \quad Hf(x) = f(x) * \frac{1}{\pi x} = \hat{f}(x) \left[ \frac{1}{\pi x} \right]^\wedge \quad \text{with } \hat{f}(x) = e^{-\pi x^2}$$

resp. 
$$FHF^{-1} = 2\pi F\left(\frac{1}{\pi x}\right) = -i \operatorname{sgn}(x) .$$

We mention Euler's famous formula ([NNi] N. Nielsen, chapter IX, §51)

$$\operatorname{sign}(x) = \frac{2}{\pi} \int_0^\infty \frac{\sin(tx)dt}{t} .$$

As link to a well known Zeta function constant we mention ([BPe] B. E. Peterson, 1.15, [RBr] R. P. Brent)

$$\left[ P.f. \frac{1}{|x|} \right]^{\wedge} = -2\gamma - 2\log|\xi| \quad ,$$

whereby P.f. denotes Hadamard's "partie finie" or "finite part". The P.v. distribution (\*) can be calculated, which we state in

To make a rigorous presentation of the Hilbert transform theory one have to apply distribution theory. We state some main properties of the Hilbert transform in

**Lemma:** For the Hilbert transform it holds

$$\text{i) } \|H\| = 1 \quad , \quad H^* = -H \quad , \quad H^2 = -I \quad , \quad H^{-1} = H^3 \quad ,$$

$$\text{ii) } H(f * g) = f * Hg = Hf * g \quad , \quad f * g = -Hf * Hg$$

$$\text{iii) } \text{If } (\varphi_n)_{n \in \mathbb{N}} \text{ is an orthogonal system, so it is for the system } (H(\varphi_n))_{n \in \mathbb{N}} \text{ , i.e.}$$

$$(H\varphi_n, H\varphi_n) = -(\varphi_n, H^2\varphi_n) = (\varphi_n, \varphi_n) \cdot$$

$$\text{iv) } \|Hu\|^2 = \|u\|^2 \text{ , i.e. if } u \in L_2 \text{ then } Hu \in L_2 \text{ .}$$

For other properties related e.g. to rotations we refer to [St] E.M. Stein.

The specific properties of the Hilbert operator we summaries in

**Lemma:** The Hilbert Operator fulfills

$$\text{i) } \text{The Fourier term for } \nu = 0 \text{ is } (Hu)_0 = 0$$

$$\text{ii) } H(xu(x)) = xH(u(x)) - \frac{1}{\pi} \int_{-\infty}^{\infty} u(y) dy$$

$$\text{iii) } \text{for odd functions it hold } H(xu(x)) = x(Hu)(x)$$

$$\text{iv) } Hu(x) = u(x) * \frac{1}{\pi x} \quad , \quad \frac{1}{\pi x} = \lim_{\rho \rightarrow 0} \frac{x}{\pi(x^2 + \rho^2)}$$

$$\text{v) } \text{If } u, Hu \in L_2 \text{ then } u \text{ and } Hu \text{ are orthogonal, i.e. } \int_{-\infty}^{\infty} u(y)(Hu)(y) dy = 0 \cdot$$

**Lemma:** The Hilbert transform of the Gauss-Weierstrass density function  $f(x) := e^{-\pi x^2}$  and its related Fourier transform are given by

$$\text{i) } [H(f)](x) = 4\pi \int_0^{\infty} f(\xi) \sin(2\pi\xi x) d\xi \quad ,$$

$$\text{ii) } [H(f)]^\wedge(\omega) = 2\pi i \int_0^\infty f(\xi) [\delta(\omega - 2\pi\xi) - \delta(\omega + 2\pi\xi)] d\xi$$

$$\text{iii) } H\left(\frac{1}{x} f\left(\frac{1}{x}\right)\right) = \frac{1}{x} (Hf)\left(\frac{1}{x}\right) \quad .$$

**Proof:**

i) The Fourier transform of  $\varphi_0(t) := \pi^{-1/4} e^{-t^2/2}$  is given by  $\hat{\varphi}_0(\omega) := \sqrt{2\pi}^{1/4} e^{-\omega^2/2}$ . From this we get

$$[H(\varphi_0)]^\wedge(\omega) = -i \operatorname{sgn}(\omega) \hat{\varphi}_0(\omega) \quad .$$

Applying the inverse Fourier transform then gives

$$[H(\varphi_0)](t) = \sqrt{2\pi}^{1/4} \int_{-\infty}^{\infty} (-i \operatorname{sgn}(\omega)) e^{-\omega^2/2} e^{-i\omega t} d\omega \quad .$$

Since  $\operatorname{sgn}(\omega) e^{-\omega^2/2}$  is odd we have

$$[H(\varphi_0)](t) = 2\sqrt{2\pi}^{1/4} \int_0^\infty e^{-\omega^2/2} \sin(\omega t) d\omega \quad .$$

With  $f(x) = \pi^{1/4} \varphi_0(\sqrt{2\pi}x)$  it follows

$$\pi^{1/4} [H(\varphi_0)](\sqrt{2\pi}x) = 2\sqrt{2\pi}^{1/4} \int_0^\infty e^{-\omega^2/2} \sin(\sqrt{2\pi}\omega x) d\omega \quad .$$

Substituting the variables  $\omega = \sqrt{2\pi}\xi$  then leads to

$$[H(f)](x) = 4\pi \int_0^\infty e^{-\pi\xi^2} \sin(2\pi\xi x) d\xi \quad .$$

Using  $\text{Fourier}[(f'(x))] = i\omega \text{Fourier}(f)(\omega)$  the same argument leads to the Hermite transform of  $\varphi_1(t)$ .

ii) We recall the Fourier transforms

$$g_1(x) := \sin(2\pi x) \qquad \hat{g}_1(\omega) = \frac{i}{2} [\delta(\omega - 2\pi) - \delta(\omega + 2\pi)]$$

$$g_2(x) := \begin{cases} \frac{i}{2} \pi \operatorname{sign}(x) & |x| \leq 2a \\ 0 & |x| > 2a \end{cases} \quad \hat{g}_2(\omega) = \frac{\sin 2(a\omega)}{\omega} \quad ,$$

which leads to ii)

iii) As  $f(x)$  is an even function it follows that  $[H(f)](x)$  is even. From the previous lemma it then follows

$$H\left(\frac{1}{x} f\left(\frac{1}{x}\right)\right) = \frac{1}{x} (Hf)\left(\frac{1}{x}\right) \quad \bullet$$

The weighted Hermite polynomials (e.g. [St] R.S. Strichartz, 7.6)

$$\varphi_n(x) := \frac{e^{-\frac{x^2}{2}} H_n(x)}{\sqrt{2^n n!} \sqrt{\pi}} \quad \text{with} \quad H_n(x) := (-1)^n e^{x^2} \frac{d^n}{dx^n} e^{-x^2}, \quad H_0(x) = 1, \quad H_1(x) = x,$$

form a set of orthonormal functions in  $L_2(-\infty, \infty)$ , i.e. the Hermite polynomials have only real zeros. The relation to the Gauss-Weierstrass density function is given by

$$f(x) = \pi^{1/4} \varphi_0(\sqrt{2\pi}x) \cdot$$

The Hermite polynomials  $H_n(x)$  fulfill the recursion formula

$$H_n(\sqrt{2\pi}x) = 2xH_{n-1}(\sqrt{2\pi}x) - (n-1)b_n\varphi_{n-2}(x) - 2(n-1)H_{n-2}(\sqrt{2\pi}x) \cdot$$

Using the abbreviation

$$a_n := \sqrt{\frac{2(n-1)!}{n!}} \quad b_n := \sqrt{\frac{(n-2)!}{n!}}$$

this gives the recursion formula

$$\varphi_n(x) := a_n x \varphi_{n-1}(x) - (n-1)b_n \varphi_{n-2}(x), \quad \varphi_0(x) := \pi^{-1/4} e^{-\frac{x^2}{2}}, \quad \varphi_1(x) := 2^{-1/2} \pi^{-1/4} x e^{-\frac{x^2}{2}},$$

from which the recursion formula for the corresponding Hilbert transforms of the Hermite polynomials can be derived, i.e.

$$\hat{\varphi}_n(x) := a_n \left[ x \hat{\varphi}_{n-1}(x) - \frac{1}{\pi} \int_{-\infty}^{\infty} \varphi_{n-1}(y) dy \right] - (n-1)b_n \hat{\varphi}_{n-2}(x)$$

$$\hat{\varphi}_0(x) = \pi^{1/4} \int_{-\infty}^{\infty} e^{-\frac{\omega^2}{2}} \sin(\omega x) d\omega \cdot$$

The simplest version of the harmonic oscillator is the Hamiltonian system with Hamiltonian

$$H(p, q) = \frac{1}{2}(p^2 + \omega^2 q^2) \quad \text{and} \quad \dot{q} = p, \quad \dot{p} = -\omega q, \quad \ddot{q} = -\omega^2 q$$

Identifying  $R^2 \cong C$  by putting  $z = p + i\omega q$  a solution to  $H(p, q) = \frac{1}{2}|z|^2$  is given in the form

$$z(t) = Ce^{i\omega t} .$$

The Hermite polynomials are used to model the energy states of the harmonic quantum oscillator.

A complex function is called Hermitian if its real part is even and its imaginary part is odd. If  $g(t)$  is a real function, then e.g.  $\hat{g}(\xi)$  is Hermitian and therefore  $|\hat{g}(\xi)|^2$  is even.

A complex signal  $u$  is called a strong analytical signal if it holds  $Hu = iu$ . For strong analytical signals  $u$  it holds  $H(\text{Re}(u)) = \text{Im}(u(x))$ , i.e.

$$z(t) = u(t) + iH(u(t))$$

is a strong analytical signal. From this, the combination of Hermite polynomials with its Hilbert transforms in the form

$$z_n(t) = \varphi_n(t) + i\widehat{\varphi}_n(t)$$

defines an alternative orthogonal system for the solution space of the harmonic quantum oscillator. This might provide an alternative model for the zero point energy of the harmonic quantum oscillator, which might overcome current inconsistencies between the Casimir effect (i.e. existing radiation at absolute zero point of the temperature) and the calculated infinite energy density from the harmonic quantum operator model.

The Maxwell equations follow the U(1)-symmetry. It basically says that a photon is symmetric to itself. U(1) is diffeomorph to the unit circle, consisting of all complex numbers with absolute value 1 under the multiplication operation. U(1) is the rotation group in the (q,p)-plane, which plays a key role for the quantum harmonic oscillator. The invariance of U(1) gives the root cause of the existence of the Leiter (creation or annihilation) operators:

$$H_{klassig} = \frac{1}{2}(p - ix)(p + ix) = a^* a$$

$$H_{quantum} = \frac{1}{2}(P^2 + Q^2) = A^* A + \frac{1}{2}\bar{1} \quad , \quad H_{quantum} = \frac{1}{2}(P^2 + Q^2) = AA^* - \frac{1}{2}\bar{1} .$$

From [RSt] R.S. Strichartz, 7.6, we recall the



**Lemma A.1:** Suppose  $\varphi$  is an eigenfunction of  $H$  with eigenvalue  $\lambda$ . Then  $A^*\varphi$  is an eigenfunction with eigenvalue  $\lambda+2$ , and  $A\varphi$  is an eigenfunction (as long as  $\lambda \neq 0$ ) with eigenvalue  $\lambda-2$ .

The link of “Hamiltonian function” to (complementary) variational principles referring to [Ve] W. Velte, 6.2.4, which is called the method of Noble.

Let  $(E, \langle \cdot, \cdot \rangle)$  and  $(E', \langle \cdot, \cdot \rangle)$  be Hilbert spaces and  $T : E \rightarrow E'$ ,  $T^* : E' \rightarrow E$  linear operators fulfilling  $(u', Tu) = \langle T^*u', u \rangle$  and let  $W : E' \times E \rightarrow \mathbb{R}$  a functional fulfilling

$$T = \frac{\partial W(u', \cdot)}{\partial u'} \quad \text{and} \quad T^* = \frac{\partial W(\cdot, u)}{\partial u}$$

i.e. the operators  $T$  and  $T^*$  are deviations from  $W(\cdot, \cdot)$  in the sense of Gateaux, i.e.

$$\lim_{t \rightarrow 0} \frac{F(u+tv) - F(u)}{t} = F'_u(u)(v) \quad \text{for all } v \in E.$$

Putting  $W(u', u) := \frac{1}{2}(u', u') - F(u)$  the minimization problem

$$(*) \quad J(u) := (Tu, Tu) + 2F(u) \rightarrow \min_{u \in U \subset E}$$

leads to  $Tu = u'$  and  $(T^*u', \cdot) = -F'_u(\cdot)$  and therefore to

**Lemma A.2** (method of Noble): If  $F(\cdot)$  is a convex functional it follows that  $W(u', u)$  is convex concerning  $u'$  and concave concerning  $u$ . The minimization problem (\*) is equivalent to the variational equation

$$(v', T\varphi) + F'_u(\varphi) = 0 \quad \text{for all } \varphi \in U \quad \text{resp.} \quad (T^*v', \varphi) = -F'_u(\varphi) \quad \text{for all } \varphi \in U.$$

i.e. there is a characterization of the solution of (\*) as a saddle point.

## 10. Lie Groups, fundamental forces and “particle physics”

There are 4 fundamental forces of Nature:

the weak, electromagnetic, strong and gravitational forces.

All of them are handled within the domain of “particle physics”, i.e. the action of forces are studied and modelled in relation to particles (accelerations). Current gauge theories are based on the concept of Lie groups, trying to unite all fundamental forces of Nature in one unified field theory:

1. Maxwell theory, based on  $U(1)$ , unites electricity & magnetism,
2. Weinberg-Salam model, based on  $SU(2) \otimes U(1)$ , unites the weak force with the electricity force,
3. GUTs, based on  $SU(5) \otimes O(10)$  or larger groups, are proposed as candidate to unite the strong force with electroweak force,
4. Superstrings are under discussion to unite gravity with the rest of the particle forces. The naive merger of general relativity and quantum mechanics produces a divergent theory, quantum gravitation, which assumes that gravitation is caused by the exchange of particle-like gravitons. Superstring theory proposes that the gravitation is caused by the exchange of closed strings instead.

Unitäre Matrizen  $U(n, C) = \{A \in M(n, n) \mid A^T A^* = E_n\}$

Spezielle unitäre Matrizen  $SU(n, C) = \{A \in U(n, C) \mid \det A = 1\}$

$$U(1) \otimes SU(n) = U(n)$$

$$SU(1, C) = \{E_1\}, \quad U(1, C) = \{cis(\beta) \mid \beta \in R\} \cong S^1 = \{z \in C \mid z = e^{i\alpha}\} \cong R/Z \cong U(1) / SU(1) \subseteq C,$$

$$SU(2, C) = \text{group of quaternions of absolute value 1} = \left\{ X = \begin{pmatrix} x_3 & x_1 - ix_2 \\ x_1 + ix_2 & -x_3 \end{pmatrix} \right\}$$

$SU(2, C)$  diffeomorph to the 3-sphere

hermitisch, complex, 2 invariants:  $\det X = -x_1^2 - x_2^2 - x_3^2 = -\vec{r}^2$  und  $Spur(X) = 0$

$SU(3, C)$  “Farb” bzw “flavor” group of the order 3, baryons interaction

$SU(5, C)$  Gruppe der grossen Vereinigung der Wechselwirkungen der Ordnung 5

$(V, d)$  unitärer Vektorraum über komplexem Zahlenkörper  $C$ ,  $d(*,*)$  positive definit, hermitisch; jede unitäre Matrix  $A$  lässt sich zerlegen in

$$A = e^{i\alpha} 1_2 A' \leftrightarrow U(2) = U(1) \otimes SU(2)$$

Wechselwirkung	Vermittler
Gravitation	Graviton
Schwach	$W^+, W^-, Z^0$
Elektromagnetisch	Photon
Stark	Gluon

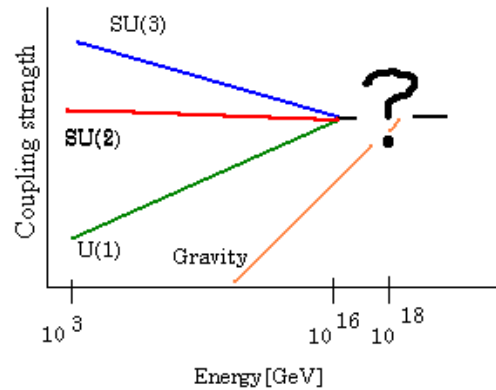

## SU(2)

Die nächst höhere Symmetrieart ist SU(2): group of quaternions of absolute value =1, diffeomorph to the 3-sphere;

Die elektroschwache Theorie stellt ein Beispiel für diese Symmetrieart dar, denn diese Symmetrie ermöglicht den Austausch von Elektronen und Neutrinos, ohne dass dabei die Gleichungen verändert werden. Zwischen Elektronen und Neutrinos besteht also Symmetrie. Und weil diese Theorie auch die Maxwell'sche Theorie mit einbezieht, kann sie sich durch die kombinierte  $U(2) = U(1) \otimes SU(2)$  Symmetrie beschreiben lassen. Diese Symmetrie erlaubt praktisch den Austausch von Elektronen, Neutrinos und Photonen, ohne dass dabei die Gleichungen verändert werden. Zwischen Elektronen, Neutrinos und Photonen existiert also eine Symmetrie.

## SU(3)

Die starke Kraft (QCD) kann wiederum durch die SU(3)-Symmetrie beschrieben werden, weil diese Symmetrieart drei Teilchen austauschbar macht. Dabei handelt es sich um die drei Farbladungen (rot, blau, grün) des Quarks.

## SU(5)

Die SU(5)-Symmetrie ermöglicht schließlich die Austauschbarkeit von fünf Teilchen (das Elektron, das Neutrino und die drei Farbladungen des Quarks), ohne dass dabei die Gleichungen verändert werden.

The goal of string theory is to explain the "?" in the above diagram.

The characteristic energy scale for quantum gravity is called the Planck Mass, and is given in terms of Planck constant, the speed of light, and Newton's constant,

$$M_{pl} = \sqrt{\hbar c / G_N} = 1.22 * 10^{19} \text{ GeV} / c^2$$

While the Standard Model has been very successful in describing most of the phenomenon that we can experimentally investigate with the current generation of particle accelerators, it leaves many unanswered questions about the fundamental nature of the universe. The goal of modern theoretical physics has been to find a "unified" description of the universe. This has historically been a very fruitful approach. For example Einstein-Maxwell theory unifies the forces of electricity and magnetism into the electromagnetic force. The Nobel prize winning work of Glashow, Salam, and Weinberg successfully showed that the electromagnetic and weak forces can be unified into a single electroweak force. There is actually some pretty strong evidence that the forces of the Standard Model should all unify as well. When we examine how the relative strengths of the strong force and electroweak force behave as we go to higher and higher energies, we find that they become the same at an energy of about  $10^{16}$  GeV. In addition the gravitational force should become equally important at an energy of about  $10^{19}$  GeV.

## Scattering

Example: Coulomb-Streuung von Elektronen an einem negativ geladenen Streuzentrum.

Betrachte dazu folgende Abbildung. Zuerst wird ein Teilchen mit Stoßparameter  $b$  (rote Bahn) gestreut, dann das gleiche Teilchen mit Stoßparameter  $b + db$  (grüne Bahn).

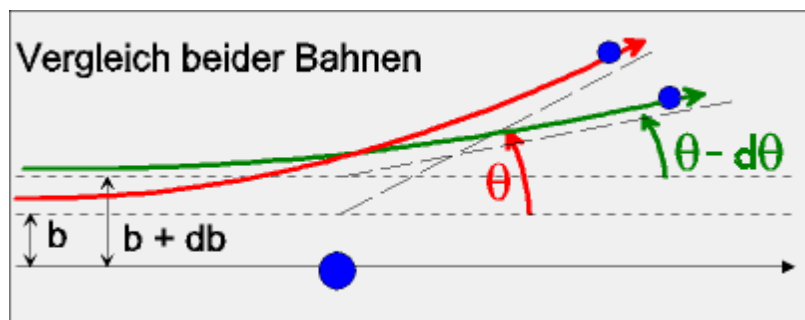

Man erkennt, dass eine Vergrößerung des Stoßparameters um  $db$  zu einer Streuwinkelverkleinerung  $d\theta$  führt.

Betrachten wir nun die Situation in Flugrichtung. Neben einer Vergrößerung  $db$  (red) des Stoßparameters könnte man die Bahn des Elektrons auch so ändern, dass es an der Stelle durch die Zielscheibe fliegt, die durch eine Drehung um den Winkel  $d\phi$  (green) aus der ursprünglichen Stelle hervorgeht (in Abbildung rechts als Drehung um  $d\phi$  (green) nach rechts dargestellt).

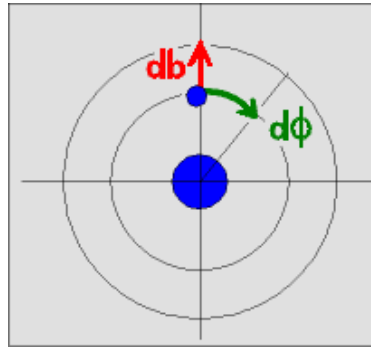

Fasst man alle Kombinationen der beiden Änderungen  $db$  und  $d\phi$  (oder kleinere) zusammen, kann man auch eine kleine Fläche  $d\sigma$  als mögliche Menge aller Änderungen betrachten. (siehe Abbildung links; Blick in Flugrichtung!).  $d\sigma$  stellt eine kleine Änderung des Wirkungsquerschnitts dar. Die Länge des kleinen Kreisbogens (grüner Pfeil in Abb. rechts) ist  $bd\phi$ . Somit gilt:

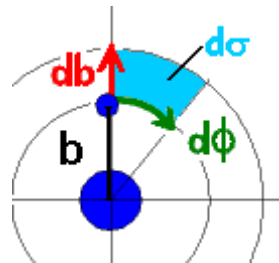

$$d\sigma = b \cdot d\phi \cdot db$$

**Wohin wird ein Teilchen gestreut, wenn seine Flugrichtung wie in rechter Abb. um  $d\phi$  verändert wird?**

Wenn wir voraussetzen, dass das für die Streuung verantwortliche Potential radialsymmetrisch ist, also nur vom Abstand abhängt, ändert sich nichts!

! Das Teilchen beschreibt auch nach der Streuung eine Flugbahn, die gegenüber der unveränderten Bahn um  $d\phi$  verdreht“ ist.

Wohin wird ein Teilchen gestreut, dessen Flugbahn durch  $d\sigma$  geht?

Dazu betrachten wir kurz die Abbildungen rechts. Die linke Abbildung zeigt die Ebene senkrecht zur Flugrichtung, durch die das Teilchen vor der Streuung fliegt. Wir nehmen an, dass das Teilchen irgendwo durch die orange Teilfläche fliegt. Die rechte Abbildung steht hinter dem Streuzentrum und stellt sozusagen eine Zielscheibe dar. Teilchen, die vorne durch die orange Teilfläche geflogen sind, treffen im Ziel alle in die rote Teilfläche.

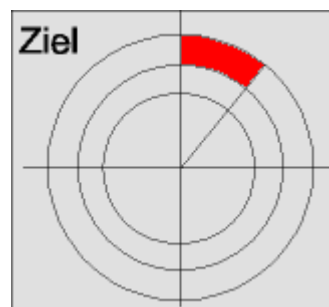
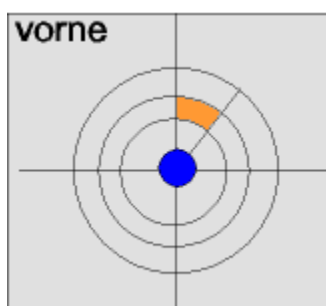

Geht nun ein Teilchen durch  $d\sigma$  (hellblaue Teilfläche vorne), so wird es schwächer gestreut. Es muss also im Bereich der dunkelblauen Teilfläche auf die Zielscheibe treffen.

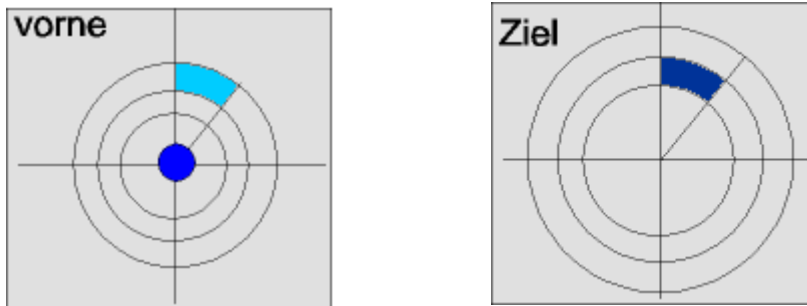

Im direkten Vergleich der beiden Fälle sieht man, wie sich die Streurichtung verändert, wenn ein Teilchen durch  $d\sigma$  fliegt. Dazu sind im unteren Abbildungspaar jeweils beide Teilflächen eingezeichnet. Folgende Flächen gehören zusammen: orange zu rot und hellblau zu dunkelblau.

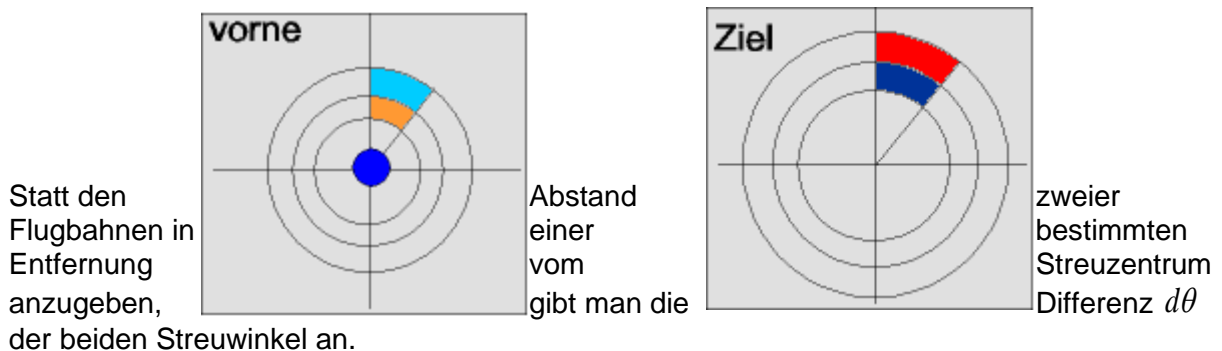

Analog dazu gibt man statt einer Teilfläche in einer bestimmten Entfernung vom Streuzentrum einen sogenannten Raumwinkel an. Einen Raumwinkel bestimmt man dadurch, dass man alle Punkte des Randes einer Fläche (z.B.  $A_D$ , siehe rechts) mit dem Mittelpunkt verbindet. Ist  $r$  der Radius der Kugel, auf deren Oberfläche man die Teilfläche  $AD$  betrachtet, so gilt für den Raumwinkel  $\Omega$  der Zusammenhang:

□□□□□□□□□□□□□□□□

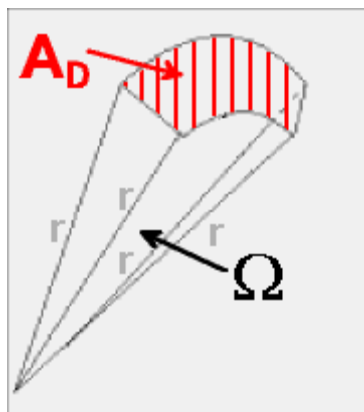

$$\Omega = A_D / r^2$$

Für ein (infinitesimal) kleines Raumwinkelement schreibt man  $d\Omega$ .

Die zentrale Aussage über die Flugbahn eines Teilchens lautet:

Teilchen, die durch  $d\sigma$  fliegen, werden in ein Raumwinkelement  $d\Omega$  gestreut.

Die folgende Abbildung veranschaulicht eine entsprechende Flugbahn, man blickt dabei von der Seite auf die Bahn (**rot**).

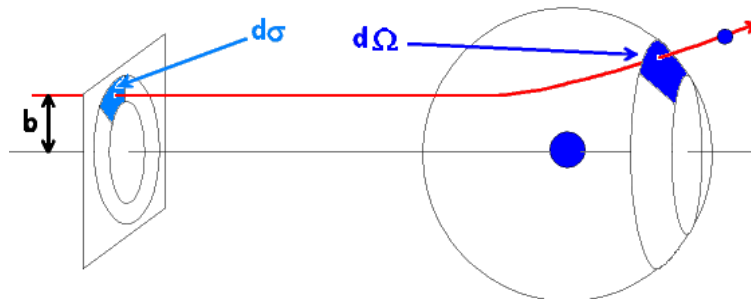

**Wie kann man aus der Kenntnis des Streuwinkels  $\theta$  auf die Größe des Stoßparameters  $b$  schließen?**

Das Coulomb-Potential  $U(r)$  ist bekannt. Zwei Ladungen ( $q$  und  $q'$ ), die Vielfache der Elementarladung  $e$  sind ( $q = Ze$  und  $q' = Z'e$ ), besitzen folgende potenzielle Energie:

$$V(r) = \frac{ZZ'e^2}{4\pi\epsilon_0 r}$$

$\epsilon_0$  ist die elektrische Feldkonstante. Durch geometrische Überlegungen und die Benutzung der Energieerhaltung (Anfangsenergie  $E = \frac{mv^2}{2} = \text{const}$ ) errechnet man folgenden Zusammenhang:

$$b = \frac{ZZ'e^2}{8\pi\epsilon_0 E} \cot\left(\frac{\theta}{2}\right)$$

Da  $Z, Z', e$  und  $E$  Konstanten sind gilt:

$$b \approx \cot\left(\frac{\theta}{2}\right)$$

Der Stoßparameter ist proportional zum Kotangens des halben Streuwinkels!

Man kann den Zusammenhang leicht umformen:

$$b \frac{8\pi\epsilon_0 E}{ZZ'e^2} = \cot\left(\frac{\theta}{2}\right)$$

Daran kann man folgendes erkennen:

a) Erhöht man nur die Energie  $E$ , wird die linke Seite der Gleichung größer, damit auch der  $\cot\left(\frac{\theta}{2}\right)$ . Das bedeutet aber, dass  $\theta$  kleiner werden muss (siehe Abbildung rechts).

Anschaulich kann man es sich so vorstellen, dass je *schneller* das Teilchen ist, desto weniger wird es gestreut.

b) Erhöht man nur  $Z$  oder  $Z'$ , nimmt also stärker geladene Teilchen, so wird die linke Seite kleiner, da  $Z$  und  $Z'$  im Nenner stehen, damit muss  $\theta$  größer werden. Anschaulich bedeutet dies, dass die Streuung umso größer ist, je stärker die Teilchen oder das Target geladen sind.

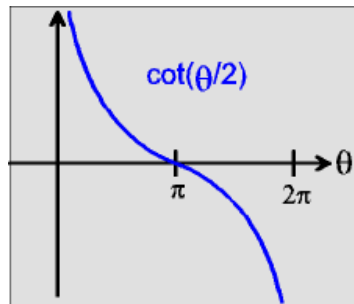

Das beschriebene Verhalten entspricht den Erwartungen, die man an die Coulomb-Streuung stellt.

### Was bedeutet dies für die Auswertung der Messergebnisse?

Im Prinzip ist es ganz einfach. Betrachten wir dazu den *Rutherford'schen Streuversuch*. Bei der Streuung der  $\alpha$ -Teilchen ( $Z = 2$ ) an Goldatomen ( $Z' = 79$ ) muss man die Energie  $E$  der  $\alpha$ -Teilchen und den zugehörigen Streuwinkel  $\theta$  bestimmen. Daraus kann nach obigem Zusammenhang der Stoßparameter berechnet werden.

Man fand Abweichungen vom Streugesetz für ganz kleine Stoßparameter. Daraus schloss man, dass für kleine Stoßparameter etwas „Neues“ passiert. Dies war ein Hinweis auf die Größe der Teilchen. Sie „berühren“ sich und verändern damit das aufgrund des Streugesetzes erwartete Ergebnis.

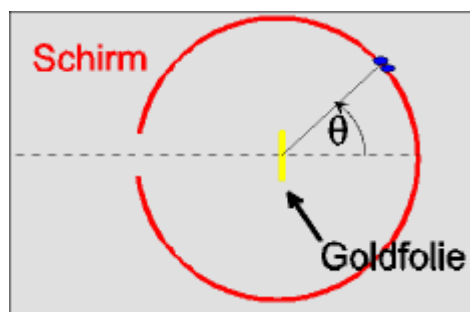

Der Stoßparameter  $b$  kann aus der Messung der Teilchenenergie und des Streuwinkel  $\theta$  bestimmt werden. Der Stoßparameter ist proportional zum Kotangens des halben Streuwinkels.



## Diffraction

If we look at the shadow cast by an opaque object, we would find that it is very intricate. In fact, the shadow would consist of bright and dark regions which are not expected from everyday geometrical optics. This is known as diffraction, and it was first shown in the 1600s to be a general characteristic of wave phenomenon which occurs whenever a portion of a wavefront is obstructed in some way. In particular, if a wave encounters an obstacle, then diffraction occurs when a region of the wavefront is altered in amplitude or phase.

It is important to realize that there is not physical difference between interference and diffraction. However, it is traditional to consider a phenomenon as interference when it involves the superposition of only a few waves, and as diffraction when a large number of waves are involved. Another aspect that is important to understand is the fact that every optical instrument only uses a portion of the full incident wavefront. Because of this, diffraction plays a significant role in the detailed understanding of the light train through the device. Even in all of the potential defects in the lens system were eliminated, the ultimate sharpness of the image would be limited by diffraction.

In order to begin to understand diffraction, let's return to Huygen's principle. Recall that this told us that each point on a wavefront can be viewed as a source of secondary spherical wavelets. From this, the progress of the wavefront as it moves through space can theoretically be determined. At any particular time, the shape of the wavefront is made up from the envelope of the secondary wavelets. There is a problem with this approach. In only considering the envelope of the secondary wavelets, Huygen's principle ignores most of the secondary wavelet and retains only the portion which is common to the envelope. As a result of this, Huygen's principle is unable to account for the details of the diffraction process. An example of this can be seen by comparing radio and visible light waves. Radio waves are seen to "bend" around large objects, such as buildings and telephone poles, but visible light creates a fairly distinct shadow. Huygen's principle is independent of any wavelength consideration and predicts the same wavefront configuration in both situations.

This problem was resolved when Fresnel added to Huygen's principle with the idea of interference. The resulting principle, known as the HuygensFresnel principle, states that every unobstructed point of a wavefront, at a given instant in time, serves as a source of spherical secondary wavelets, with the same frequency as that of the primary wave. The amplitude of the optical field at any point beyond is the superposition of all these wavelets, taking into consideration their amplitudes and relative phases. As an example of this, consider the following drawing

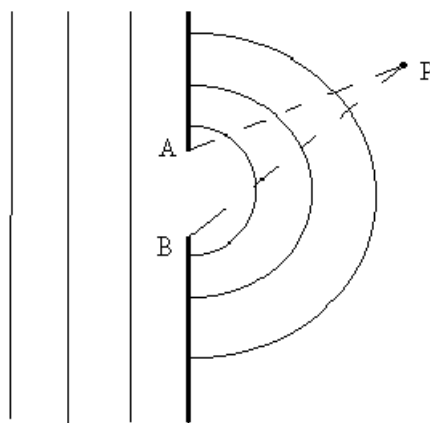

Define the maximum optical path length difference as  $\Lambda_{\max} = \left| \overline{AP} - \overline{BP} \right|$ . Assume that  $\overline{AB} \geq \Lambda_{\max}$ . Then when  $\lambda \gg \overline{AB}$ , we also have that  $\lambda \geq \Lambda_{\max}$ . Since the waves were

initially in phase, they must all interfere constructively, no matter where P happens to be. On the other hand, when  $\lambda \ll \overline{AB}$ , the area where  $\lambda \gg \Lambda_{\max}$  is limited to a small region extending out directly in front of the aperture, and it is only there that all of the wavelets interfere constructively. Beyond this region, some of the wavelets can interfere destructively. This is the geometric shadow. Remember that the idealized geometric shadow corresponds to  $\lambda \rightarrow 0$ .

### The Circular Aperture

Fraunhofer diffraction through a circular aperture can be found in a manner similar to that used for the rectangular aperture. In this case, instead of using rectangular coordinates, the symmetry of the situation dictates the use of cylindrical coordinates. It holds

$$E = \frac{E_A e^{i(kR-at)}}{R} \int_0^a \int_0^{2\pi} e^{i(kq\rho/R)\cos(\phi-\Phi)} \rho d\rho d\phi,$$

The quantity

$$J_0(u) = \frac{1}{2\pi} \int_0^{2\pi} e^{iu\cos v} dv$$

is known as a Bessel function of the first kind. Comparing it to the azimuthal integral above we see that

$$E = \frac{E_A e^{i(kR-at)}}{R} 2\pi \int_0^a J_0\left(\frac{kq\rho}{R}\right) \rho d\rho$$

Using the recurrence relationship for Bessel functions,

$$uJ_1(u) = \int_0^u vJ_0(v)dv$$

where

$$J_1(u) = \frac{-i}{2\pi} \int_0^{2\pi} e^{i(v+u\cos v)} dv,$$

this can be evaluated as

$$E = \frac{E_A e^{i(kR-at)}}{R} 2\pi a^2 \frac{1}{ka \sin \theta} J_1(ka \sin \theta)$$

where the relationship  $\sin \theta = \frac{q}{R}$  was used. The irradiance becomes

$$E = 2 \left[ \frac{E_A A}{R} \right]^2 \left[ \frac{J_1(ka \sin \theta)}{ka \sin \theta} \right]^2 .$$

At the center of the aperture, the irradiance is

$$I(0) = \frac{1}{2} \left[ \frac{E_A A}{R} \right]^2 \quad \text{and so it holds} \quad I(\theta) = I(0) \left[ \frac{2J_1(ka \sin \theta)}{ka \sin \theta} \right]^2 .$$

## 11. Differential forms, duality relation between Cartan and Co-derivatives

Examples for q-forms in  $M = R^3 ( (a, b, \dots, k) \text{ are functions of } x, y, z )$  are:

$$\text{0-form } \Phi = \Phi(x, y, z), \quad d\Phi = \frac{\partial f}{\partial x} dx + \frac{\partial f}{\partial y} dy + \frac{\partial f}{\partial z} dz$$

$$\text{1-form } \lambda = adx + bdy + cdz, \quad d\lambda = \left(\frac{\partial c}{\partial y} - \frac{\partial b}{\partial z}\right) dydz + \left(\frac{\partial a}{\partial z} - \frac{\partial c}{\partial x}\right) dzdx + \left(\frac{\partial b}{\partial x} - \frac{\partial a}{\partial y}\right) dxdy$$

$$\text{2-form } \mu = fdy \wedge dz + gdz \wedge dx + hdx \wedge dy, \quad d\mu = \left(\frac{\partial f}{\partial x} + \frac{\partial g}{\partial y} + \frac{\partial h}{\partial z}\right) dxdydz$$

$$\text{3-form } \nu = kdx \wedge dy \wedge dz, \quad d\nu = 0$$

$$\text{k-forms } (q > 3) \quad \rho = 0. \quad (\text{general form } \omega = \sum_{\mu_1 \mu_2 \dots \mu_k} \omega_{\mu_1 \mu_2 \dots \mu_k} dx^{\mu_1} \wedge dx^{\mu_2} \dots \wedge dx^{\mu_k}).$$

With the notation  $\vec{a} = (a, b, c)$ ,  $\vec{v} = (f, g, h)$ ,  $d\vec{x} = (dx, dy, dz)$ ,  $dA = (dydx, dzdx, dxdy)$ ,  $dV = dxdydz$  this gives (note  $d \wedge f = df$ )

$$\text{0-form } \Phi = \Phi(\vec{x}), \quad d\Phi = \text{grad}\Phi d\vec{x}$$

$$\text{1-form } \lambda = \vec{a} d\vec{x}, \quad d\lambda = \text{rot}\vec{a} dA$$

$$\text{2-form } \mu = \vec{v} dA, \quad d\mu = (\text{div}\vec{v}) dV.$$

For the polar coordinates in dimension 4, given by

$$x = r * e_1 = r \sin \vartheta \cos \varphi \sin \xi$$

$$y = r * e_2 = r \sin \vartheta \sin \varphi \sin \xi$$

$$z = r * e_3 = r \cos \vartheta \sin \xi$$

$$w = r * e_4 = r \cos \xi$$

it holds 
$$\left| \frac{d(x, y, z, w)}{d(r, \varphi, \vartheta, \xi)} \right| = r^3 \sin \vartheta \sin^2 \xi,$$

$$|dV| = r^3 dr d\varphi \sin \vartheta \sin^2 \xi d\vartheta d\xi \quad dA = \frac{dV}{dr} = r^2 d\varphi \sin \vartheta \sin^2 \xi d\vartheta d\xi.$$

Let  $M$  be a  $n$ -dimension, oriented semi-Riemann manifold and  $\Omega^k M$  be the vector space of the differentiable  $k$ -forms on  $M$  (note that  $\Omega^0 M = C^\infty(M)$ ). Each  $\omega \in \Omega^k M$  is a skew symmetric  $(0,k)$ - tensor on  $M$ , i.e. a  $C^\infty - (0,k)$  tensor field on  $M$ .

Especially a  $(0,2)$ - tensor on  $M$  is a symmetric, positive definite bilinear form, which is also called the metric tensor (the fundamental tensor or the metric), i.e. a  $C^\infty - (0,2)$  (i.e. twofold covariant) tensor field on  $M$ .

Let  $\omega_M$  the volume form of  $M$ . The pointwise building of the scalar product of two forms  $\eta, \zeta \in \Omega^k M$  defines a function  $\langle \eta, \zeta \rangle \in C^\infty(M)$ . Its integration over  $M$  (with compact intersection of their support) via the volume form  $\omega_M$  gives a real number, i.e.

$$\langle \langle \eta, \zeta \rangle \rangle := \int_M \langle \eta, \zeta \rangle \omega_M .$$

For every  $k$  there is a linear mapping  $*$ :  $\Omega^k M \rightarrow \Omega^{n-k} M$  that for all  $\eta, \zeta \in \Omega^k M$  it holds

$$\eta \wedge * \zeta = \langle \eta, \zeta \rangle \omega_M$$

This operator is called the Hodge operator. It holds

$$** = Id \quad \text{and} \quad d \circ d = 0 .$$

The electromagnetic field is described by the Faraday tensor:

Let  $\vec{\vec{F}} = (F_{ik})$  be the Faraday tensor, defined by

$$\vec{\vec{F}} = (F_{ik}) = \begin{pmatrix} 0 & E^1 & E^2 & E^3 \\ -E^1 & 0 & -B^3 & B^2 \\ -E^2 & B^3 & 0 & -B^1 \\ -E^3 & -B^2 & B^1 & 0 \end{pmatrix} .$$

Applying the Hodge operator to this tensor  $* \vec{\vec{F}} = (* F_{ik})$ , which is the Maxwell tensor, keeps the full information about the field, because the Hodge operator is an isomorphism:

$$* \vec{\vec{F}} = (* F_{ik}) = \begin{pmatrix} 0 & -B^1 & -B^2 & -B^3 \\ B^1 & 0 & -E^3 & E^2 \\ B^2 & E^3 & 0 & -E^1 \\ B^3 & -E^2 & E^1 & 0 \end{pmatrix} .$$

Both tensors are differential form of order 2. For the Maxwell equations (1) and (2) the following equivalent formulations are valid:

$$(1) \Leftrightarrow d * \vec{\vec{F}} = * 4\pi I \quad , \quad (2) \Leftrightarrow d \vec{\vec{F}} = 0 .$$

We note the two Poicare lemmata:

1. Poincare lemma: for each differential form  $F$  it holds  $d(dF) = 0$
2. Poincare lemma: for each differential form  $F$  with  $dF = 0$  for an open domain of a point  $P$  there exists a differential form  $G$  with  $dG = F$  .

The Co derivation  $\delta : \Omega^{n-k} M \rightarrow \Omega^{n-k-1} M$  , defined by

$$\delta := (-1)^k * d *^{-1}$$

is the formal adjoint (dual) operator of  $d$ , i.e. it holds

**Theorem** (duality equation for the Cartan derivative): For  $\eta \in \Omega^k M$  and  $\zeta \in \Omega^{k+1} M$  with compact intersection of their support in  $M - \partial M$  it holds

$$\langle\langle d\eta, \zeta \rangle\rangle = -\langle\langle \eta, \delta\zeta \rangle\rangle .$$

For  $M = R^3$  it holds

- i)  $*1 = dx \wedge dy \wedge dz = dV \in \Omega^3 M$  (and therefore  $*dV = 1$ ).
- ii)  $*dx = dy \wedge dz$  ,  $*dy = dz \wedge dx$  ,  $*dz = dx \wedge dy$  .

For vector fields  $v$  and  $w$  it holds in local coordinates

$$\langle v, w \rangle := g_{\mu\nu} v^\mu w^\nu = v_\mu w^\mu .$$

For 1-forms  $\alpha$  and  $\beta$  it holds in local coordinates

$$\langle \alpha, \beta \rangle = \alpha_\mu \beta^\mu = g^{\mu\nu} \alpha_\mu \beta_\nu , \quad \text{especially} \quad \langle dx^\mu, dx^\nu \rangle = g^{\mu\nu} .$$

A symplectic manifold is a pair  $(M^{2m}, \omega)$ , where  $M^{2m}$  is a manifold with an even dimension and  $\omega$  a closed, 2-form, i.e.  $d\omega = 0$  and  $\omega^m := \omega \wedge \omega \wedge \dots \wedge \omega \neq 0$  with its volume  $2m$ -form

$$dM^{2m} = \frac{(-1)^{m(m-1)/2}}{m!} \omega^m$$

Its relation to Hamilton is given by  $(M^{2m}, \omega) := (R^{2m}, \sum_1^m dp_i \wedge dq_i)$  given

$$\omega^m = m!(-1)^{m(m-1)/2} dp_1 \wedge dp_2 \wedge \dots \wedge dp_m \wedge dq_1 \wedge dq_2 \wedge \dots \wedge dq_m .$$

The term

$$\sum_1^m \left( \frac{\partial H}{\partial p_i} \frac{\partial}{\partial q_i} - \frac{\partial H}{\partial q_i} \frac{\partial}{\partial p_i} \right)$$

motivates the definition a symplectic gradient for a function  $H : M^{2m} \rightarrow R$  on a symplectic manifold:

The symplectic gradient  $s - grad(H)$  is the vector field on  $M^{2m}$  defined by

$$\omega(\vec{V}, s - grad(H)) := dH(\vec{V}) .$$

### **Invariant vector and tensor fields, flow of vector fields, Lie derivative and its geometric interpretation as divergence of vector fields as its infinitesimal volume deformation of its flow**

Let  $\vec{V}$  be a vector fields of a manifold  $M^n$  and  $\gamma : (a, b) \rightarrow M^n$  an integral curve of  $\vec{V}$  with tangential vector  $\dot{\gamma}(t) = \vec{V}(\gamma(t))$ . Therefore there exists to every initial point  $x \in M^n$  an integral curve  $\gamma_x : (a_x, b_x) \rightarrow M^n$  with  $\gamma_x(0) = x$ . For

$$\Sigma_{\vec{V}} := \{(t, x) \in R \times M^n \mid a_x < t < b_x\}$$

the mapping

$$\Phi : \Sigma_{\vec{V}} \rightarrow M^n$$

$$\Phi(t, x) := \gamma_x(t)$$

Is called the flow of the vector field  $\vec{V}$ .

If  $\vec{V}$  is a  $C^\infty$  vector field, then  $\vec{V}$  operates on  $C^\infty$  scalar fields to give  $C^\infty$  scalar fields. The Lie derivation  $L_{\vec{V}}$  with respect to  $\vec{V}$  is an extension of this operation to an operator on all tensor fields which preserves type of tensor fields, i.e.  $L_{\vec{V}}$  is a tensor field of the same type

as  $\vec{V}$ . The **Lie derivation** of a differential k-form  $\omega^k$  by a related vector field is defined as follows:

$$L_{\vec{V}}(\omega^k) = \frac{d}{dt}(\Phi_t^*(\omega^k))_{t=0} = \lim_{t \rightarrow 0} \frac{\Phi_t^*(\omega^k) - \omega^k}{t} \text{ for } t \rightarrow 0 .$$

The **Lie derivation** of a k-form  $\omega^k$  can be calculated by the Cartan derivative, i.e.

$$L_{\vec{V}}(\omega^k) = i_{\vec{V}}(d\omega^k) + d(i_{\vec{V}}(\omega^k)) ,$$

whereby  $i_{\vec{V}}(\omega^k)(W_1, \dots, W_{k-1}) := \omega^k(\vec{V}, W_1, \dots, W_{k-1})$  is the inner product of  $\vec{V}$  and  $\omega^k$ .

The **divergence of a vector field**  $A \subset M^n$  vanishes if and only if its flow consists of volume conserving diffeomorphisms.

Examples of invariant vector fields

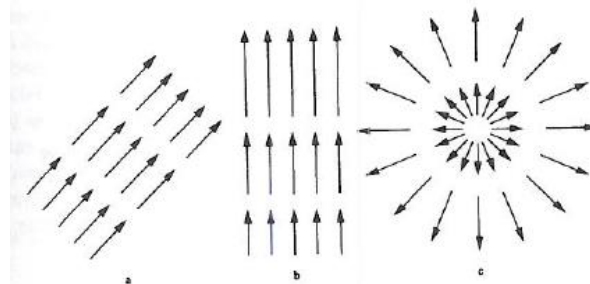

Invariant (translation parallel (a), senkrecht (b) to the vector field, rotation (c)) vector fields in  $R^2$

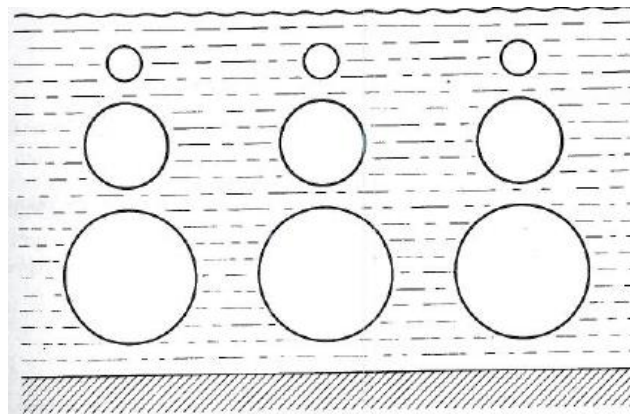

Invariant symmetric tensor field of second order: Indicatrix field of the stress?? tensor of a liquid in the gravitation field

**Theorem of Liouville:** Let  $H$  be a function  $H : M^{2m} \rightarrow R$  on a symplectic manifold and its symplectic gradient  $s - grad(H)$  a complete vector field on  $M^{2m}$  with the flow

$\Phi_t : M^{2m} \rightarrow M^{2m}$  then it holds:

i) the Lie derivative  $L_{s-grad(H)}(\omega) = 0$  vanishes

ii) the flow keeps the symplectic volume, i.e.  $\int_A dM^{2m} = \int_{\Phi_t(A)} dM^{2m}$ .

In the Ricci calculus the Cartan derivative  $d : \Omega^k M \rightarrow \Omega^{k+1} M$  of a k-form and the volume form of  $M$  is given by

$$d(\omega^k) = d\left(\sum_{i_1 < \dots < i_k} w_{i_1 < \dots < i_k} dx^{i_1} \wedge dx^{i_2} \dots \wedge dx^{i_k}\right)$$

$$d(\omega^k) = \sum_{i_1 < \dots < i_k} \sum_{\alpha=1}^n \frac{\partial w_{i_1 < \dots < i_k}}{\partial x^\alpha} dx^\alpha \wedge dx^{i_1} \wedge dx^{i_2} \dots \wedge dx^{i_k}$$

$$\omega_M = \sqrt{|g|} dx^1 \wedge dx^2 \dots \wedge dx^n = \sqrt{|g|} dR^n.$$

For a 1-form  $\alpha \in \Omega^1 M$  the term  $\partial\alpha$  is called the divergence of the vector field  $v = \alpha^\mu \partial_\mu$ . It holds

$$d * \alpha = \frac{1}{\sqrt{|g|}} \sum_{\mu=1}^n \partial_\mu (\sqrt{|g|} \alpha^\mu) \omega_M \quad \text{and} \quad \delta \alpha = \frac{1}{\sqrt{|g|}} (\sqrt{|g|} \alpha^\mu) \cdot$$

For functions (i.e. 0-forms  $\omega^0 = f$ ) the relation to the Laplace operator is given by

**Theorem:** The Laplace operator  $\Delta := \delta d := \Omega^0 M \rightarrow \Omega^0 M$  with

$$\Delta f = \delta df = (-1)^{K+1} * d * df$$

applied to functions on a semi-Riemann manifold is given in local coordinates by

$$\Delta f = \frac{1}{\sqrt{|g|}} \sum_{\mu, \nu=1}^n \frac{\partial}{\partial x^\mu} \partial_\mu (\sqrt{|g|} g^{\mu\nu} \frac{\partial}{\partial x^\nu} f).$$

The Laplace operator for function on  $S^2$  in spherical coordinates is given by

$$\Delta_{S^2} = \frac{1}{\sin^2 \vartheta} \frac{\partial^2}{\partial \varphi^2} + \frac{1}{\sin \vartheta} \frac{\partial}{\partial \vartheta} (\sin \vartheta \frac{\partial}{\partial \vartheta}).$$

For  $R^{n+1}$  with its n-dimensional sub manifold

$$S^n := \{x \in R^{n+1} \mid \|x\| = 1\}$$

and the pseudo-euclidian scalar product with signature  $(n,1)$ , the Hodge-Laplace operator is given by



$$\Delta f = \frac{\partial^2 f}{\partial^2 x^1} + \frac{\partial^2 f}{\partial^2 x^2} + \dots + \frac{\partial^2 f}{\partial^2 x^n} - \frac{\partial^2 f}{\partial^2 x^{n+1}} .$$

**Theorem (Stokes):** Let  $M$  be a n-dimension, oriented semi-Riemann manifold and  $\omega \in \Omega^{n-1}M$  have a compact support. Then it holds

$$\int_M d\omega = \int_{\partial M} \omega .$$

$$M \subset R^3 : \int_{M^2} \langle \text{rot} \vec{a}, N \rangle dM^2 = \int_{\partial M^2} \langle \text{rot} \vec{a}, T \rangle d\partial M^2 , \quad \int_{M^2} \text{rot} \vec{a} d\vec{A} = \int_{\partial M^2} \vec{a} d\vec{s} .$$

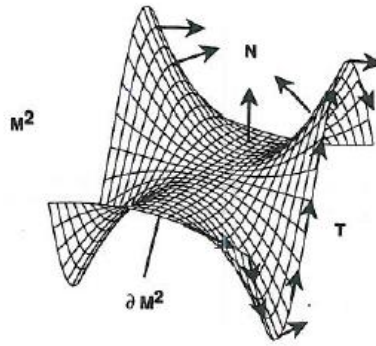

**Theorem (Satz vom gekämmten Igel):** Ein stetig gekämmter Igel hat mindestens einen Glatzpunkt. Every differentiable vector field on a even-dimensional sphere has at least one zero (or a even-dimensional sphere has no vector field without any zero).

I.M. Singer, J. Thorpe (the curvature of 4-dimensional Einstein spaces, Global analysis, papers in honour of K. Kodaira, p. 355-365, Princeton Univ. Press 1969) discovered a result of A. Einstein related to especially **duality of 4 dimensional manifolds**:

Let  $(M, g)$  a 4 dimensional oriented Riemann manifold,  $*$  the self adjoint Hodge operator and  $R$  the (self adjoint) Riemann curvature tensor, then it holds

$$(M, g) \text{ is an Einstein space} \quad \Leftrightarrow \quad * \circ R = R \circ * .$$

In the framework of the differential form calculus the Maxwell equations are given in the form

$$* d\omega_E = -\frac{1}{c} \left( \frac{\partial}{\partial t} \omega_B \right) , \quad d(*\omega_B) = 0$$

$$* d\omega_B = \frac{1}{c} \left( \frac{\partial}{\partial t} \omega_E \right) + \frac{4\pi}{c} \omega_J , \quad d(*\omega_E) = 4\pi \rho dR^3 .$$

## 12. Variation principle and principle of relativity

Minimizing a certain quantity ( $\delta W = 0$ ) as principle seems to bring a **purpose** to the **causal** description of things. In the light of the discoveries of relativity, the variational foundation of mechanics deserves more than purely formalistic appraisal. The following points suggest the supremacy of the variational method:

1. The principle of Relativity requires that the laws of nature shall be formulated in a „invariant“ fashion, i.e. independently of any special frame of reference. The method of the calculus of variations automatically satisfies this principle, because the minimum of a scalar quantity does not depend on the coordinates in which that quantity is measured. While the Newtonian equations of motion did not satisfy the principle of relativity, the principle of least action remain valid, with the only modification that the basic action quantity had to be brought into harmony with the requirement of invariance.
2. The Theory of General Relativity has shown that matter cannot be separated from field and is in fact an outgrowth of the field. Hence the basic equations of physics must be formulated as partial differential equation (Nahwirkungstheorie). While Newton´s particle picture can hardly be brought into harmony with the field concept, the variational methods are not restricted to the mechanics of particles but can be extended to the mechanics of continua.
3. The Theory of General Relativity is automatically satisfied if the fundamental „action“ of the variational principle is chosen as an invariant under any coordinate transformation. Since differential geometry of Riemann furnishes such invariants, there are no difficulties in setting up the required field equations. Apart from this, the present knowledge of mathematics does not give any clou to the formulation of a co-variant, and at the same time consistent, system of field equations.

**Hence in the light of relativity the application of the calculus of variations to the laws of nature assumes more than accidental significance.**

$$\delta f = \varepsilon \left( \frac{\partial f}{\partial \varepsilon} \right)_{\varepsilon=0} \text{ virtuelle Verschiebung, for } f(v, v')$$

$$df = \frac{\partial f}{\partial v} dv + \frac{\partial f}{\partial v'} dv' \quad \text{and} \quad \delta f = \frac{\partial f}{\partial v} \delta v + \frac{\partial f}{\partial v'} \delta v'$$

i.e. Variation  $\delta f$  einer Funktion  $f(v, v')$  wird also in derselben Weise gebildet wie ihr vollständiges Differential. The displacement of the position  $\delta x$  is intentionally made in any kinematic ally admissible manner.

Unter einer virtuellen Verschiebung versteht man eine *gedachte* sehr kleine Verschiebung  $\delta x$ . Während wirkliche Verschiebungen immer in einer bestimmten Zeit  $dt$  erfolgen, wird die virtuelle Verschiebung als zeitlos angesehen,  $\delta t = 0$ . Variationen von Kurven werden so gewählt  $\delta \vec{r}_i(t_1) = \delta \vec{r}_i(t_2) = 0$  Die Zeit wird nicht mit variiert:  $\delta t = 0$ , d.h. jeder Zeitpunkt der Variationskurven entspricht nur einem Zeitpunkt der Referenzkurve.

$$\rightarrow \delta \dot{\vec{r}} = \frac{d}{dt} \delta \vec{r}$$

Das Hamilton'sche Prinzip ist äquivalent zu dem d'Alembertschen Prinzip.

In Lorentz-invarianten Feldtheorien ist es üblich, Feldgleichungen nicht einfach zu postulieren, sondern aus einem Variationsprinzip herzuleiten. Dadurch wird automatisch die Existenz von Erhaltungssätzen gesichert (Noether-Theorem) und ausserdem eine Grundlage für die Quantisierung (Schwingersches Variationsprinzip, Feynmansches Wegintegral) geschaffen.

With Lorentz-invariant field theory one tries to derive field equation out of variation principle. Then Noether's theorem is valid, which ensure conservation laws.

For Einstein's vacuum equation in the gauges this leads to expressions in the form

$$W_{metric} = \int R \sqrt{-g} d^4x = \int g^{ik} R_{ik} \sqrt{-g} d^4x ,$$

with

$$R \sqrt{-g} = \sqrt{-g} g^{ik} R_{ik} , \quad R = g^{ik} R_{ik}$$

The general field equations of the Theory of General Relativity say, that the action

$$W[g, \phi] = W_{metric}[g] + W_{matter}[g, \phi]$$

is stationary for all fields  $\phi$ , varying over all metrics, which vanish outside bounded domains. The action is local, i.e. an integral over a Lagrange density and invariant for variable transforms.

The choice of spherical wave coordinates  $x^\alpha$  for Einstein's vacuum equation in the gauges is given by the wave equation relative to the background metric  $g$ , i.e.

$$\square_g = \frac{1}{\sqrt{|g|}} \partial_\mu g^{\mu\nu} \sqrt{|g|} \partial_\nu x^\alpha = 0 .$$

Applying the principle of least action, i.e.

$$\delta W[g, \phi] = \delta [W_{metric}[g] + W_{matter}[g, \phi]] = 0$$

leads to ( $\mu = 8\pi$ )

$$-\frac{c^3}{16\pi k} \int \left[ R_{ik} - \frac{1}{2} g_{ik} R - \frac{8\pi k}{c^4} T_{ik} \right] \delta g^{ik} \sqrt{-g} d^4x = 0 .$$

As  $\delta g^{ik}$  is arbitrarily this gives Einstein's field equation in the form

$$G = R_{ik} - R \frac{g_{ik}}{2} = \frac{8\pi}{c^4} T_{ik} \quad \text{resp.} \quad R_i^k - \frac{1}{2} \delta_i^k R = \frac{8\pi}{c^4} T_i^k .$$

Proof:

In order to show the above we first calculate

$$\delta W_{metric}[g] = \delta W_g = \int R \sqrt{-g} d^4 x = \int g^{ik} R_{ik} \sqrt{-g} d^4 x$$

$$\delta W_g = \int \left[ R_{ik} \sqrt{-g} \delta g^{ik} + R_{ik} g^{ik} \delta \sqrt{-g} + g^{ik} \sqrt{-g} \delta R_{ik} \right] d^4 x$$

With

$$\delta \sqrt{-g} = -\frac{1}{2\sqrt{-g}} \delta g = -\frac{1}{2} \sqrt{-g} g_{ik} \delta g^{ik}$$

it follows

$$\delta W_g = \int \left[ R_{ik} \sqrt{-g} - \frac{1}{2} g_{ik} R \right] \delta g^{ik} \sqrt{-g} d^4 x + \int g^{ik} \delta R_{ik} \sqrt{-g} d^4 x .$$

The Grössen  $\Gamma_{kl}^i$  nämlich bilden keinen Tensor, wohl hingegen  $\delta \Gamma_{kl}^i$  was man ausnutzt, um  $\delta R_{ik}$  zu berechnen. Es ist nämlich  $\Gamma_{kl}^i A_k dx^l$  die Änderung eines Vektors bei der Parallelverschiebung von irgendeinem Punkt  $P$  zum infinitesimal benachbarten  $P'$ . Daher stellt  $\delta \Gamma_{kl}^i A_k dx^l$  die Differenz zweier Vektoren dar, die bei den zwei Parallelverschiebungen (mit nichtvariierten und mit variierten  $\Gamma_{kl}^i$ ) von  $P$  nach demselben Punkt  $P'$  erhalten werden. Die Differenz zweier Vektoren im gleichen Punkt ist aber ein Vektor;  $\delta \Gamma_{kl}^i$  ist somit ein Tensor.

Ein lokalgeodätisches Koordinatensystem zugrundegelegt, für das in einem vorgegebenem Punkt alle  $\Gamma_{kl}^i = 0$  sind, ergibt sich aufgrund von

$$R_{ik} = \frac{\partial \Gamma_{ik}^l}{\partial x^l} - \frac{\partial \Gamma_{il}^l}{\partial x^k} - \Gamma_{ik}^l \Gamma_{lm}^m - \Gamma_{il}^m \Gamma_{km}^l$$

für  $R_{ik}$  das folgende

$$g^{ik} \delta R_{ik} = g^{ik} \left[ \frac{\partial}{\partial x^l} \delta \Gamma_{ik}^l - \frac{\partial}{\partial x^k} \delta \Gamma_{il}^l \right] = g^{ik} \frac{\partial}{\partial x^l} \delta \Gamma_{ik}^l - g^{ik} \frac{\partial}{\partial x^k} \delta \Gamma_{il}^l = \frac{\partial w^l}{\partial x^l}$$

mit dem Vektor

$$w^l = g^{ik} \delta \Gamma_{ik}^l - g^{il} \delta \Gamma_{lk}^k .$$

$$\delta W_m = \delta W_{matter}[g, \phi] = \frac{1}{2c} \int T_{ik} \delta g^{ik} \sqrt{-g} d^4 x .$$

$$\delta W_g + \delta W_g = 0 \quad \Rightarrow \quad -\frac{c^3}{16\pi k} \int \left[ R_{ik} - \frac{1}{2} g_{ik} R - \frac{8\pi k}{c^4} T_{ik} \right] \delta g^{ik} \sqrt{-g} d^4 x = 0$$

Das Thema ist Materie und Bewegung, genauer: Energie und Impuls; Energie und Impuls hängen wegen der Relativität der gleichförmigen Bewegung untrennbar zusammen.

Die Struktur der Raum-Zeit bestimmt ihren Inhalt, aber auch ihr Inhalt legt die Struktur fest; Struktur und Inhalt hängen also wechselseitig voneinander ab.

Der Wechsel von Newton bezieht sich auf einen Wechsel von der Potentialgleichung für das Gravitationsfeld:

$$\Delta\Phi = 4\pi k\rho$$

und die zugehörigen Bewegungsgleichungen eines Massenpunktes

$$\frac{d^2\bar{x}}{dt^2} = -\text{grad}\Phi$$

hin zu Einsteins Feldgleichungen für das tensorielle Gravitationsfeld

$$G = R_{ik} - R \frac{g_{ik}}{2} = -kT_{ik}$$

und die zugehörigen Bewegungsgleichungen für die Bahn  $x^\mu = x^\mu(t)$  eines Massenpunktes

$$\frac{d}{d\tau} \left( g_{\mu,\nu} \frac{dx^\mu}{d\tau} \right) = \frac{1}{2} \frac{\partial g_{\alpha\beta}}{\partial x^\nu} \frac{\partial x^\alpha}{\partial \tau} \frac{\partial x^\beta}{\partial \tau} \dots$$

Riemann curvature tensor is defined by

$$R_{ijkk}^s = \partial_j \Gamma_{ki}^s - \partial_k \Gamma_{jk}^s + \Gamma_{jr}^s \Gamma_{ki}^r - \Gamma_{kr}^s \Gamma_{ji}^r .$$

This curvature tensor has  $4^4 = 256$  components.

It about

- 10 Gleichungen mit 10 Potentialen  $\Phi_{ik}$  anstelle von einer Gleichung

- nicht-linearer Zusammenhang, d.h. das Gravitationspotential ist keine Summe von Einzelgravitationen

Zirkuläre Struktur, d.h.  $\Phi_{ik} = f(T_{ik})$  und *Raum-Zeit-Struktur* =  $f(\Phi_{ik})$ . Die  $T_{ik}$  sind Größen, die das Prinzip der Energie- und Impulserhaltung widerspiegeln.

Die Materie, beschrieben mit dem Energie-Impuls-Tensor T, erzeugt also über die Einsteinsche Feldgleichung

$$G := R_{ik} - \frac{1}{2} R g_{ik} = Ricci + Weyl = -\kappa T_{ik}$$

wobei  $\kappa = 8\pi G c^2 \approx 1.86 \cdot 10^{-27} \text{ cm/g}$  eine Krümmung der Raumzeit, und Teilchen bewegen sich dann entlang von Geodäten. Die Gleichung, die Materie und Krümmung in Beziehung setzt, muss tensorieller Natur sein. Zur Beschreibung der Materie steht der Energie-Impuls-Tensor zur Verfügung. Da dieser zweifach covariant ist, muss zur Beschreibung der Krümmung auch ein (0,2)-Tensor verwendet werden. Zunächst bietet sich der Ricci-Tensor  $R_{ik}$  an. Im Gegensatz zum Energie-Impuls-Tensor ist dieser aber nicht divergenzfrei. Dieser Mangel lässt sich beheben, indem ein geeignetes Vielfaches von  $R^* g$  subtrahiert wird. Damit erweist sich  $G$  als divergenzfrei und ist mit dem Energie-Impuls-Tensor in Beziehung zu setzen. Im Vergleich mit der Newtonschen Mechanik ergibt sich  $\mu = 8\pi$ . Divergenzfrei wäre auch

$$G = R_{ik} - R \frac{g_{ik}}{2} - \lambda g$$

Warum der Term  $-R \frac{g_{ik}}{2}$ ? Es gilt

$$\text{div}(Rg) = dS \quad \text{und} \quad \text{div}(R_{ik}) = \frac{dS}{2}$$

und damit

$$\text{div}(R_{ik}) - \frac{1}{2} \text{div}(Rg_{ik}) = \frac{dS}{2}.$$

Der Weyl-Tensor  $R \frac{g_{ik}}{2}$  beschreibt den „Gezeiten-Effekt“, während der Ricci-Tensor die Energie beschreibt. Weyl ist eine Art „Gravitationsgegenstück“ zur Grösse des elektromagnetischen Feldes. Somit stellt Weyl in gewisser Weise ein Mass für das Gravitationsfeld dar. Die „Quelle“ für Weyl ist der Tensor=Energie (=Ricci), analog zur Maxwell'schen Theorie, wo die Quelle für das elektromagnetische Feld  $(E, B)$  durch  $(\rho, j)$ , die Gesamtheit der Ladungen und Ströme, gegeben ist.

Es gilt u.a.:

$$R \sqrt{-g} = \sqrt{-g} g^{ik}, \quad R = g^{ik} R_{ik}$$

Die Divergenz von  $A^p$  ist die Verjüngung der kovarianten Ableitung bzgl.  $x_q$  d.h. die Verjüngung von  $A^p_{,q}$

$$\text{Div}(A^p) = \frac{1}{\sqrt{-g}} \frac{d}{dx^k} [\sqrt{-g} A^k]$$

### 13. Singularitäten in der Allgemeinen Relativitätstheorie

Das "potentialtheoretische" Problem der Existenz überall regulärer Lösungen der Einsteinschen Vakuum-Feldgleichungen  $R_{ik} = 0$  (Einsteins "Partikel-Problem") ist von der Frage des Auftretens dynamischer Singularitäten in der ART sehr verschieden. Wenn die Einsteinschen Gleichungen

$$R_{ik} - \frac{1}{2} g_{ik} R = -\kappa T_{ik}$$

als Definitionsgleichungen für den Materie-Tensor  $T_{ik}$  aufgefaßt werden, so treten an die Stelle der 10 Feldgleichungen nur noch 2 Ungleichungen  $R \geq 0$ ,  $R_0^0 \leq \frac{1}{2} T$  die die Kausalität der Zustandsgleichungen für die Materie verlangen, wegen der  $T \geq 0$ ,  $T_0^0 \geq \frac{1}{2} T$  sein muß.

Aber genau diese Ungleichungen für die Raumkrümmung ergeben den Kollaps; bzw. Anti-Kollaps der Sterne, Systeme und des Kosmos ("Big bang").

"Regular solutions of Einstein equations" mean very different things. In the case of the empty-space equations,  $R_{ik} = 0$ , such solutions must be metrics  $g_{ik}(x^l)$  without additionally singular "field sources" (Einstein's "particle problem") - However the "phenomenological matter" is defined by the Einstein equations

$$R_{ik} - \frac{1}{2} g_{ik} R = -\kappa T_{ik}$$

itself. Therefore if 10 regular functions  $g_{ik}(x^l)$  are given (which the inequalities of Lorentz-signature fulfill then these  $g_{ik}$  define 10 functions  $T_{ik}(x^l)$  without singularities. But, the matter-tensor  $T_{ik}$  must fulfill the two inequalities  $T \geq 0$ ,  $T_0^0 \geq \frac{1}{2} T$  only and therefore the Einstein

equations with "phenomenological matter" mean the two inequalities  $R \geq 0$ ,  $R_0^0 \leq \frac{1}{2} T$  which are incompatible with a permanently regular metric with Lorentz-signature, generally. But exactly this inequations for the curvature of the space give the collapse resp. the anti collapse of stars and systems of the universe ("big bang").

#### 14. Ueber das Gravitationsfeld eines Massenpunktes nach der Einsteinschen Theorie, K. Schwarzschild



Die Schwarzschild-Geometrie eignet sich, um in erster Näherung das Gravitationsfeld von Sternen relativistisch zu beschreiben. Die äussere Schwarzschild-Geometrie beschreibt das Feld eines Massepunktes ausserhalb des Sternes und ist die Metrik nicht rotierender, ungeladener Schwarzer Löcher. Der Massepunkt mit Masse M ist idealisiert, weil seine Masse in einem beliebig kleinen Punkt komprimiert ist. Das schwarze Loch vom Schwarzschild-Typ hat hier eine zentrale, punktförmige Krümmungssingularität.

Die Metrik ist statisch und kugelsymmetrisch. Der metrische Tensor ist wie die Minkowski-Metrik diagonal, aber die Einträge sind nicht konstant, sondern koordinatenabhängig und divergieren bei  $r=0$  in der zentralen Singularität.

Nach dem Birkhoff-Theorem ist jede sphärische symmetrische Vakuumlösung (Vakuumlösung= ein verschwindender Energie-Impulstensor) der Einsteinschen Feldgleichungen notwendigerweise statisch. Das gilt also im Speziellen für die äussere Schwarzschild-Lösung.

Eine Folge dieser Metrik ist:

Wenn die Masse eines Sternes in einer sphärischen Region konzentriert ist, die so klein ist, dass die Masse geteilt durch den Radius einen bestimmten kritischen wert übersteigt, ist die resultierende Raumzeitkrümmung so stark, das ALLES, auch das Licht, sich der Gravitationsanziehung nicht mehr entziehen kann --> schwarze Löcher

> alles was den Ereignishorizont (=dunkler Kreis) überschreitet --> puff

Die innere Schwarzschild-Geometrie beschreibt das innere Feld unterhalb der Sternoberfläche.

Schwarzschild-Lösung kann in einer Vielzahl von Koordinatensystemen diskutiert werden.

Ein Punkt bewegt sich gemaess der Forderung

$$(1) \quad \delta \int ds = \delta \int \sqrt{\sum_{\mu, \nu=1}^4 g_{\mu\nu} dx_\mu dx_\nu} = 0$$

Die Ausführung der Variation ergibt die Bewegungsgleichungen des Punktes

$$(2) \quad \frac{d^2 x_\alpha}{ds^2} = \sum_{\mu, \nu} \Gamma_{\mu\nu}^\alpha(x) \frac{dx_\mu}{ds} \frac{dx_\nu}{ds}$$

wobei

$$(3) \quad \Gamma_{\mu\nu}^\alpha(x) = -\frac{1}{2} \sum_{\beta} g^{\alpha\beta} \left[ \frac{\partial g_{\mu\beta}}{\partial x_\nu} + \frac{\partial g_{\nu\beta}}{\partial x_\mu} - \frac{\partial g_{\mu\nu}}{\partial x_\beta} \right]$$

Dies ist nach Einstein dann die Bewegung eines masselosen Punktes in dem Gravitationsfeld einer im Punkt  $x_1 = x_2 = x_3 = 0$  befindlichen Masse, wenn die

Komponenten des Gravitationsfeldes  $\Gamma$  überall, mit Ausnahme des Punktes  $x_1 = x_2 = x_3 = 0$ , den Feldgleichungen

$$(4) \quad \sum_{\alpha} \frac{\partial \Gamma_{\mu\nu}^{\alpha}(x)}{\partial x_{\alpha}} + \sum_{\alpha, \beta} \Gamma_{\mu\nu}^{\alpha}(x) \Gamma_{\mu\nu}^{\beta}(x) = 0$$

genügen und wenn gleichzeitig die Determinantengleichung

$$(5) \quad |g_{\mu\nu}| = -1$$

erfüllt ist.

Die Feldgleichungen in Verbindung mit der Determinantengleichung haben die fundamentale Eigenschaft, dass sie ihre Gestalt behalten bei der Substitution beliebiger anderer Variablen an der Stelle von  $x_1, x_2, x_3, x_4$  falls nur die Substitutionsdeterminante gleich 1 ist.

Sollen  $x_1, x_2, x_3$  rechtwinklige Koordinaten,  $x_4$  die Zeit bedeuten, soll ferner die Masse im Nullpunkt zeitlich unveränderlich sein, und soll die Bewegung im Unendlichen gleichförmig gradlinig sein, so sind noch folgende Forderungen zu erfüllen:

1. alle Komponenten sind von der Zeit  $x_4$  unabhängig
2. die Gleichungen  $g_{i4} = g_{4i} = 0$  gelten exakt für  $i = 1, 2, 3$
3. die Lösung ist räumlich symmetrisch um den Anfangspunkt des Koordinatensystems in dem Sinne, dass man wieder auf dieselbe Lösung stösst, wenn man  $x_1, x_2, x_3$  einer orthogonalen Transformation (Drehung) unterwirft
4. die  $g_{\mu\nu}$  verschwinden im Unendlichen mit der Ausnahme folgender vier von Null verschiedener Grenzwerte:  $g_{44} = 1, g_{11} = g_{22} = g_{33} = -1$

Diese Bedingungen führen auf die Schwarzschild-Metrik

$$ds^2 = \left(1 - \frac{\alpha}{R}\right) dt^2 - \frac{dR^2}{1 - \frac{\alpha}{R}} - R^2 \frac{dx_2^2}{1 - x_2^2} - R^2 (d\vartheta^2 + \sin^2 \vartheta d\varphi^2)$$

**Herleitung:** Für  $(x_1, x_2, x_3, x_4) := (x, y, z, t)$  ist das allgemeinste Linienelement, das (1)-(3) erfüllt

$$ds^2 = F dt^2 - G(dx^2 + dy^2 + dz^2) - H(xdx + ydy + zdz)^2$$

Wobei F, G, H Funktionen von  $r = \sqrt{x^2 + y^2 + z^2}$  sind.

Forderung (4) verlangt  $F(\infty) = G(\infty) = 1, H(\infty) = 0$

Wenn man zu Polarkoordinaten übergeht gemäss

$$x = r^* e_1 = r \sin \vartheta \cos \varphi$$

$$y = r^* e_2 = r \sin \vartheta \sin \varphi$$

$$z = r^* e_3 = r \cos \vartheta$$

$$J := \frac{d(x, y, z)}{d(r, \vartheta, \varphi)} = \begin{pmatrix} \sin \vartheta \cos \varphi & r \cos \vartheta \cos \varphi & -r \sin \vartheta \sin \varphi \\ \sin \vartheta \sin \varphi & r \cos \vartheta \sin \varphi & r \sin \vartheta \cos \varphi \\ \cos \vartheta & -r \sin \vartheta & 0 \end{pmatrix} \text{ and } \left| \frac{d(x, y, z)}{d(r, \vartheta, \varphi)} \right| = r^2 \sin \vartheta$$

Dann lautet dasselbe Linienelement

$$ds^2 = F dt^2 - G(dr^2 + r^2 d\vartheta^2 + r^2 \sin^2 \vartheta d\varphi^2) - H r^2 dr^2$$

$$ds^2 = F dt^2 - (G + H r^2) dr^2 - G r^2 (d\vartheta^2 + \sin^2 \vartheta d\varphi^2)$$

Das Volumenelement in Polarkoordinaten ist gleich  $r^2 \sin^2 \vartheta dr d\vartheta d\varphi$  d.h. die Funktionaldeterminanten der alten noch der neuen Koordinaten  $r^2 \sin^2 \vartheta$  ist von 1 verschieden. Es würden also die Feldgleichungen nicht in unveränderter Form bestehen, wenn man mit Polarkoordinaten rechnen würde, und man müesste eine umständliche Transformation ausführen. Ein einfacher Kunstgriff gestattet jedoch, diese Schwierigkeit zu umgehen. Man setze

$$x_1 = \frac{r^3}{3}, \quad x_2 = \cos \vartheta, \quad x_3 = \varphi$$

Dann gilt für das Volumenelement

$$r^2 \sin^2 \vartheta dr d\vartheta d\varphi = dx_1 dx_2 dx_3$$

d.h. die neuen Koordinaten sind Polarkoordinaten von der Determinante 1. Sie haben alle Vorzüge von Polarkoordinaten für die Behandlung des Problems, und zugleich bleiben für sie, wenn man  $t = dx_4$  hinzunimmt, die Feldgleichungen und die Determinantengleichung in unveränderter Form erhalten.

In den neuen Polarkoordinaten lautet das Linienelement

$$ds^2 = F dx_4^2 - \left( \frac{G}{r^4} + \frac{H}{r^2} \right) dx_1^2 - G r^2 \left[ \frac{dx_2^2}{1-x_2^2} + dx_3^2 (1-x_2^2) \right]$$

bzw.

$$(*) \quad ds^2 = f_4(x_1) dx_4^2 - f_1(x_1) dx_1^2 - f_2(x_1) \frac{dx_2^2}{1-x_2^2} - f_3(x_1) dx_3^2 (1-x_2^2) .$$

$f_1(x_1), f_2(x_1) = f_3(x_1), f_4(x_1)$  müssen folgenden Bedingungen genügen:

1. für  $x_1 \rightarrow \infty$   $f_1(x_1) = \frac{1}{r^4} = [3x_1]^{-4/3}$ ,  $f_2(x_1) = f_3(x_1) = r^2 = [3x_1]^{2/3}$ ,  $x_4 = 1$

2. die Determinantengleichung:  $f_1(x_1)f_2(x_1)f_3(x_1)f_4(x_1) = 1$

3. die Feldgleichungen

4. die f stetig, ausser für  $x_1 = 0$

(\*) and  $\Gamma_{\mu\nu}^\alpha(x) = -\frac{1}{2} \sum_\beta g^{\alpha\beta} \left[ \frac{\partial g_{\mu\beta}}{\partial x_\nu} + \frac{\partial g_{\nu\beta}}{\partial x_\mu} - \frac{\partial g_{\mu\nu}}{\partial x_\beta} \right]$  leads to

$$\Gamma_{11}^1(x) = -\frac{1}{2} \frac{1}{f_1} \frac{\partial f_1}{\partial x_1}, \quad \Gamma_{22}^1(x) = +\frac{1}{2} \frac{1}{f_1} \frac{\partial f_2}{\partial x_1} \frac{1}{1-x_2^2}, \quad \Gamma_{33}^1(x) = +\frac{1}{2} \frac{1}{f_1} \frac{\partial f_2}{\partial x_1} (1-x_2^2), \quad \Gamma_{44}^1(x) = -\frac{1}{2} \frac{1}{f_1} \frac{\partial f_4}{\partial x_1}$$

$$\Gamma_{21}^2(x) = -\frac{1}{2} \frac{1}{f_2} \frac{\partial f_2}{\partial x_1}, \quad \Gamma_{22}^2(x) = -\frac{1}{f_1} \frac{x_2}{1-x_2^2}, \quad \Gamma_{33}^2(x) = -x_2(1-x_2^2),$$

$$\Gamma_{31}^3(x) = -\frac{1}{2} \frac{1}{f_2} \frac{\partial f_2}{\partial x_1}, \quad \Gamma_{32}^3(x) = +\frac{x_2}{1-x_2^2},$$

$$\Gamma_{41}^4(x) = -\frac{1}{2} \frac{1}{f_4} \frac{\partial f_4}{\partial x_1}$$

Die Ausrechnung der Feldgleichungen (o.B.d.A.  $1-x_2^2 = 1$ )

$$\sum_\alpha \frac{\partial \Gamma_{\mu\nu}^\alpha(x)}{\partial x_\alpha} + \sum_{\alpha,\beta} \Gamma_{\mu\nu}^\alpha(x) \Gamma_{\mu\nu}^\beta(x) = 0$$

liefert

a) 
$$\frac{\partial}{\partial x_1} \left( \frac{1}{f_1} \frac{\partial f_1}{\partial x_1} \right) = \frac{1}{2} \left( \frac{1}{f_1} \frac{\partial f_1}{\partial x_1} \right)^2 + \left( \frac{1}{f_2} \frac{\partial f_2}{\partial x_1} \right)^2 + \frac{1}{2} \left( \frac{1}{f_4} \frac{\partial f_4}{\partial x_1} \right)^2$$

b) 
$$\frac{\partial}{\partial x_1} \left( \frac{1}{f_1} \frac{\partial f_2}{\partial x_1} \right) = 2 + \left( \frac{1}{f_1 f_2} \frac{\partial f_2}{\partial x_1} \right)^2$$

c) 
$$\frac{\partial}{\partial x_1} \left( \frac{1}{f_1} \frac{\partial f_4}{\partial x_1} \right) = \left( \frac{1}{f_1 f_4} \frac{\partial f_4}{\partial x_1} \right)^2.$$

Ausser diesen drei Gleichungen a)-c) haben die Funktionen  $f_1(x_1), f_2(x_1) = f_3(x_1), f_4(x_1)$  noch die Determinantengleichung zu erfüllen

d)  $f_1(x_1)f_2(x_1)f_3(x_1)f_4(x_1) = 1$  bzw.  $\frac{1}{f_1} \frac{\partial f_1}{\partial x_1} + \frac{2}{f_2} \frac{\partial f_2}{\partial x_2} + \frac{1}{f_4} \frac{\partial f_4}{\partial x_1} = 0$

Aus a), c) und d) folgt

c') 
$$\frac{\partial}{\partial x_1} \left( \frac{1}{f_4} \frac{\partial f_4}{\partial x_1} \right) = \frac{1}{f_1 f_4} \frac{\partial f_1}{\partial x_1} \frac{\partial f_4}{\partial x_1}$$

Woraus sich durch Integration ergibt:

c'') 
$$\frac{1}{f_4} \frac{\partial f_4}{\partial x_1} = \alpha f_1$$

a) und c') addiert gibt

$$\frac{\partial}{\partial x_1} \left( \frac{1}{f_1} \frac{\partial f_1}{\partial x_1} + \frac{1}{f_4} \frac{\partial f_4}{\partial x_1} \right) = \left( \frac{1}{f_2} \frac{\partial f_2}{\partial x_1} \right)^2 + \frac{1}{2} \left( \frac{1}{f_1} \frac{\partial f_1}{\partial x_1} + \frac{1}{f_4} \frac{\partial f_4}{\partial x_1} \right)^2 .$$

Verbunden mit d) folgt

$$-2 \frac{\partial}{\partial x_1} \left( \frac{1}{f_2} \frac{\partial f_2}{\partial x_1} \right) = 3 \left( \frac{1}{f_2} \frac{\partial f_2}{\partial x_1} \right)^2 .$$

Integriert ergibt sich

$$\frac{1}{\frac{1}{f_2} \frac{\partial f_2}{\partial x_1}} = \frac{3}{2} x_1 + \frac{\rho}{2} \quad \text{bzw.} \quad \frac{1}{f_2} \frac{\partial f_2}{\partial x_1} = \frac{2}{3x_1 + \rho}$$

Nochmals integriert ergibt sich  $f_2(x_1) = \lambda(3x_1 + \rho)^{2/3} .$

Die Bedingung  $f_2(\infty) = (3x_1)^{2/3}$  ergibt  $\lambda = 1 .$

Aus d) folgt  $\alpha f_1(x_1) f_4(x_1) = \frac{\alpha}{f_2^2(x_1)}$

Zusammen mit c'') ergibt sich  $\frac{\partial f_4}{\partial x_1} = \alpha f_1 f_4 = \frac{\alpha}{f_2^2(x_1)} = \frac{\alpha}{(3x_1 + \rho)^{4/3}}$

Integriert in Rücksicht auf die Bedingung im Unendlichen

$$f_4(x_1) = 1 - \frac{\alpha}{(3x_1 + \rho)^{1/3}}$$

Wiederum aus d) folgt dann  $f_1(x_1) = \frac{1}{f_4(x_1) f_2^2(x_1)} = \frac{1}{1 - \frac{\alpha}{(3x_1 + \rho)^{1/3}} \cdot (3x_1 + \rho)^{4/3}} .$

Das allgemeine Ergebnis ist also

$$f_1(x_1) = \frac{(3x_1 + \rho)^{-4/3}}{1 - \alpha(3x_1 + \rho)^{-1/3}}$$

$$f_2(x_1) = f_3(x_1) = (3x_1 + \rho)^{2/3}$$

$$f_4(x_1) = 1 - \frac{\alpha}{(3x_1 + \rho)^{1/3}} .$$

Damit sind alle Forderungen erfüllt bis auf die Stetigkeitsbedingung. Es wird  $f_1(x_1)$  unstetig, wenn  $1 - \alpha(3x_1 + \rho)^{-1/3} = 0$  (d.h.  $3x_1 = \alpha^2 - \rho$ ) gilt. Damit diese Unstetigkeit mit dem Nullpunkt zusammenfällt, muss gelten  $\alpha^2 = \rho$ . Die Unstetigkeitsbedingung verknüpft also in dieser Weise die beiden Integrationskonstanten  $\rho$  und  $\alpha$ .

Mit der Hilfsgrösse  $R := (3x_1 + \rho)^{1/3} = (3x_1 + \alpha^2)^{1/3}$  ergibt sich als Resultat

$$f_1(x_1) = \frac{1}{R^4} \frac{1}{1 - \frac{\alpha}{R}}$$

$$f_2(x_1) = f_3(x_1) = R^2$$

$$f_4(x_1) = 1 - \frac{\alpha}{R}$$

bzw.

$$ds^2 = \left(1 - \frac{\alpha}{R}\right) dx_4 - \frac{1}{R^4} \frac{1}{1 - \frac{\alpha}{R}} dx_1 - R^2 \frac{dx_2}{1 - x_2^2} - R^2 dx_3 (1 - x_2^2)$$

bzw. mit  $x_1 = \frac{r^3}{3}$   $x_2 = \cos \vartheta$   $x_3 = \varphi$

$$ds^2 = \left(1 - \frac{\alpha}{R}\right) dt^2 - \frac{dR^2}{1 - \frac{\alpha}{R}} - R^2 \frac{dx_2}{1 - x_2^2} - R^2 (d\vartheta^2 + \sin^2 \vartheta d\varphi^2) .$$

## 15. The elasticity (boundary value) problem, variational formulation

In this section we refer to the [Fi1/2], [FrK], [Pa], [Ve]. Let  $\Omega \subset R^2$  be a bounded domain with boundary  $\partial\Omega$  sufficiently smooth (such sufficient conditions could be either i) continuously

differentiable or ii) a polygon in two dimensions or iii) Lipschitz bounded).. We will work with vectors  $\underline{v} := (v_1, v_2)$ . We write  $\underline{v} := (v_1, v_2) \in \underline{L}_2 := L_2 \times L_2$  in case of  $v_i \in L_2 = L_2(\Omega)$ . The meaning of  $\underline{W}_2^1$  etc. in analogue. For simplicity we will use the notation  $\underline{H}_1 := \overset{\circ}{\underline{W}}_2^1$ ,  $\underline{H}_2 := \underline{H}_1 \cap \underline{W}_2^2$ . Correspondingly we define

$$(\underline{u}, \underline{v}) := (u_i, v_i) \text{ and } \|\underline{u}\| := \sqrt{(\underline{u}, \underline{u})}$$

$$(\nabla \underline{u}, \nabla \underline{v}) := (u_{i|k}, v_{i|k}) \text{ and } \|\nabla \underline{u}\| := \sqrt{(\nabla \underline{u}, \nabla \underline{u})}$$

using the usual summation convention throughout this section. We denote with  $X_{,i}$  the partial derivatives, with  $\delta_{ik}$  the Kronecker symbol and with  $\lambda, \mu$  the Lamé constants. To a displacement vector  $\underline{v}$  are associated the two tensors

$$\varepsilon(\underline{v}) : 2\varepsilon_{ik}(\underline{v}) = v_{i,k} + v_{k,i}$$

$$\sigma(\underline{v}) : \sigma_{ik}(\underline{v}) = \lambda(v_{j,j})\delta_{ik} + 2\mu\varepsilon_{ik} \quad .$$

The first boundary value problems of elasticity is:

$$\text{given } \underline{f} := (f_1, f_2) \in \underline{L}_2 \text{ find } \underline{u} \in \underline{H}_2 := \underline{H}_1 \cap \underline{W}_2^2$$

such that

$$(*) \quad -\nabla \sigma(\underline{u}) = \underline{f} \quad \text{i.e.} \quad -\sigma_{ik,k}(\underline{u}) = f_i \quad \text{in } \Omega_i$$

It holds the following shift theorem: For  $\underline{f} := (f_1, f_2) \in \underline{L}_2$  the solution  $\underline{u} \in \underline{H}_2$  exists uniquely and

$$\|\underline{u}\|_{\underline{W}_2^2} \leq c \|\underline{f}\|_{\underline{L}_2} \quad .$$

The solution of the boundary problem above is equivalently characterized by

$$\underline{u} \in \underline{H}_1 : a_0(\underline{u}, \underline{v}) = (\underline{f}, \underline{v}) \quad \underline{v} \in \underline{H}_1$$

with

$$(2) \quad a_0(\underline{v}, \underline{w}) := (\sigma_{ik}(\underline{v}), \varepsilon_{ik}(\underline{w})) = \iint_{\Omega} \left\{ \lambda(v_{i,i})(w_{k,k}) + 2\mu\varepsilon_{ik}(\underline{v})\varepsilon_{ik}(\underline{w}) \right\} dx \quad .$$

The form  $a_0$  is symmetric, bounded and because of Korn's inequality coercive in  $\underline{H}_1$ .

As long as we are in  $\underline{H}_1 := \overset{\circ}{\underline{W}}_2^1$  the form can be modified without influencing the solution by (whereby  $\underline{n}$  is the normal vector of  $\partial\Omega$ )

$$(2) \quad a_1(\underline{v}, \underline{w}) := a_0(\underline{v}, \underline{w}) - \oint_{\partial\Omega} n_i \{ \sigma_{ik}(\underline{v}) w_k + \sigma_{ik}(\underline{w}) v_k \} ds$$

leading to

**Lemma:** Let  $\underline{u} \in \underline{H}_1$  be the solution of (\*) and  $\underline{w} \in \underline{W}_2^1$ , then

$$a_1(\underline{u}, \underline{w}) = (\underline{f}, \underline{w}) \quad .$$

Within the framework of Hilbert space theory the coerciveness of the bilinear form (1) in the space  $\underline{H}_1 := \overset{\circ}{\underline{W}}_2^1$  is essential. This means that there is a constant  $c_1$  independent of  $\underline{H}_1 := \overset{\circ}{\underline{W}}_2^1$  such that

$$(3) \quad \|\underline{u}\|_{\underline{H}_1}^2 \leq c_1 \{ a(\underline{u}, \underline{u}) + \|\underline{u}\|^2 \} \quad \text{for all } \underline{u} \in \underline{H}_1 \quad .$$

Korn's first inequality states the validity of

$$(4) \quad \|\nabla \underline{u}\|_1^2 \leq c_2 \{ \|\varepsilon(\underline{u})\|^2 + \|\underline{u}\|^2 \} \quad \text{for } \underline{u} \in \overset{\circ}{\underline{H}}_1$$

even without the second term on the right side. Korn's second inequality is referring to the general case, i.e. (3) for all  $\underline{u} \in \underline{H}_1$  .

Beside certain regularity assumption the least square method and the energy minimization method are equivalent [Ve]. For the energy the method the energy functional minimization

$$J(u) := a(u, u) - 2(f, u) \rightarrow \min$$

and the variation formulation (see Lemma above)

$$a(u, v) = (f, v)$$

are equivalent. Non linear problem can be handled in the same framework, but now the symmetric bilinear form has to be replaced by a convex functional.

To extend this ideas to the gravitation theory we recall from section 11:

Let  $\omega_M$  the volume form of  $M$  . The pointwise building of the scalar product of two forms  $\eta, \zeta \in \Omega^k M$  defines a function  $\langle \eta, \zeta \rangle \in C^\infty(M)$  . Its integration over  $M$  (with compact intersection of their support) via the volume form  $\omega_M$  gives a real number, i.e.



$$\langle\langle\eta, \zeta\rangle\rangle := \int_M \langle\eta, \zeta\rangle \omega_M .$$

For every  $k$  there is a linear mapping  $*$ :  $\Omega^k M \rightarrow \Omega^{n-k} M$  that for all  $\eta, \zeta \in \Omega^k M$  it holds

$$\eta \wedge * \zeta = \langle\eta, \zeta\rangle \omega_M$$

This operator is called the Hodge operator. It holds

$$** = Id \quad \text{and} \quad d \circ d = 0 .$$

This differential from framework in combination with the euclidean variational (Hilbert space based) theory might enable a corresponding “action minimizing” principle on proerly defined manifolds, building on an appropriate coercive bilinear form, defined by 2-forms, which describe the curvatures of a 3-Lorentz-hypersurface (i.e. a semi riemannian 3-manifold embedded in the euclidean 4-space) modelling the gravitation (boundary or intial value ?) problem and providing a link to the wave problem in the  $n = m + 1$  euclidean 4-space.

## Hypersurface

From H. Flanders, “Differential Forms with Applications to the Physical Science” we recall some studies of surfaces of higher dimension than 1, which is about an  $m$ -dimensional manifolds  $M$  embedded in  $R^{m+1}$ , which is called a **hypersurface**  $M$ .

A moving point on  $M$  is denoted by  $x$  and a definite unit normal at each point  $x$  of  $M$  is denoted by  $\underline{n}$ . The map  $\underline{x} \rightarrow \underline{n}$  is a smooth map on  $M$  into  $S^m$ . If  $M$  is orientable this can be done globally on a hypersurface  $M$ ). The tangent space at  $x$  is an  $n$ -dimensional Euclidean space (let  $\underline{e}_i$  its ONS). Thus at  $x$ , the vectors  $\underline{e}_1, \underline{e}_2, \dots, \underline{e}_n, \underline{n}$  make up an orthogonal basis of  $R^{m+1}$ . Since  $d\underline{x}$  is in the tangent space it holds

$$d\underline{x} = \sigma_1 \underline{e}_1 + \dots + \sigma_m \underline{e}_m$$

where  $\sigma_1, \dots, \sigma_m$  are 1-forms on  $M$ . From the relations

$$\underline{e}_i \underline{e}_k = \delta_{ik} \quad , \quad \underline{e}_i \underline{n} = 0 \quad , \quad \underline{n} \underline{n} = 1$$

one deduces that

$$d\underline{e}_i \underline{e}_k + \underline{e}_i d\underline{e}_k = 0 \quad , \quad d\underline{e}_i \underline{n} + \underline{e}_i d\underline{n} = 0 \quad , \quad \underline{n} d\underline{n} = 1$$

and so

$$d\underline{e}_i = \sum \omega_{ij} \underline{e}_j - \omega_i \underline{n} \quad , \quad d\underline{n} = \sum \omega_i \underline{e}_i$$

where  $\omega_{ij}, \omega_i$  are 1-forms on  $M$  and

$$\omega_{ij} + \omega_{ji} = 0 .$$

From the matrix  $\Omega := (\omega_{ij})_{i,j=1,\dots,m}$  one defines a skew-symmetric matrix of 2-form

$$\Xi := (\theta_{ij})_{i,j=1,\dots,m} = d\Omega - \Omega^2$$

By taking exterior derivatives ( $d(d\underline{x}) = 0$ ) (omitting the symbol  $\wedge$ ) one obtains integrability conditions

$$d\sigma_i = \sum \sigma_i \omega_{ij} \quad , \quad \omega_{ij} + \omega_{ji} = 0 \quad , \quad \sum \sigma_i \omega_i = 0 \quad , \quad d\omega_i = \sum \omega_i \omega_{ij} \quad , \quad \theta_{ij} + \omega_i \omega_j = 0 \quad .$$

The  $\sigma_1, \dots, \sigma_m$  form a basis for 1-forms on M, hence we have relations

$$\omega_i = \sum b_{ij} \sigma_j \quad .$$

Because  $\sum \sigma_i \omega_i = 0$  the  $b_{ij}$  must be symmetric, i.e.  $b_{ij} = b_{ji}$  .

The mean curvature H and Gaussian curvature K are defined by

$$H = \frac{1}{m} \sum b_{ii} \quad , \quad K = |b_{ij}| \quad .$$

How does an observer constrained to M observe the motion of  $\underline{v} = \sum c_i \underline{e}_i$  ?

A vector function for which the equations

$$dc_i + \sum c_i \omega_{ij} = 0$$

are valid is said to move by parallel displacement.

The elements  $\theta_{ij}$  of the curvature matrix  $\Xi$  are curvature forms. One may write

$$2\theta_{ij} = \sum R_{ijkl} \sigma_k \sigma_l$$

defining the Riemann curvature tensor  $R_{ijkl}$  of the hypersurface. Because of the relation

$$\theta_{ij} + \omega_i \omega_j = 0$$

and

$$2\omega_i \omega_j = 2 \sum b_{ik} b_{jl} \sigma_k \sigma_l = \sum (b_{ik} b_{jl} - b_{il} b_{jk}) \sigma_k \sigma_l$$

we have

$$R_{ijkl} + \begin{vmatrix} b_{ik} & b_{il} \\ b_{jk} & b_{jl} \end{vmatrix} = 0 \quad .$$

Algebraic consequences of these formulas are the following:

$$R_{ijkl} + R_{ijlk} = 0, \quad R_{ijkl} + R_{jikl} = 0, \quad R_{ijkl} + R_{iklj} + R_{iljk} = 0, \quad R_{ijkl} = R_{klij}.$$

The Riemann tensor is independent of how  $M$  is embedded in  $R^{m+1}$  so that these relations are particularly interesting, connecting the intrinsic Riemann tensor with the quantities  $b_{ij}$ , which clearly depend on the embedding.

## 16. The Poincare conjecture

Poincare's Fragestellung war: Ist das Universum eine 3-dimensionale Mannigfaltigkeit? Wenn jede Schlaufe darin auf einen Punkt geschrunft werden kann, ist es dann eine Sphäre analog der Vorstellung von Kugeloberfläche vs. Torus für den 2-dim-Fall?

Es gibt ausser der 3-Sphäre keine 3-dimensionale geschlossene Mannigfaltigkeit, in denen jeder geschlossenen Weg sich auf einen Punkt zusammenziehen lässt, also einfach zusammenhängend ist; d.h. die 3-Sphäre ist durch ihre Fundamentalgruppe charakterisiert, d.h. die Fundamentalgruppe ist die Identität.

Die Fundamentalgruppe einer Mannigfaltigkeit ist definiert als die Menge aller Schleifen in einem Punkt, wobei zwei Schleifen als dieselben betrachtet werden, wenn sie ineinander umgeformt werden können. Die Identität ist die Schleife, die an einem einzigen Punkt bleibt und nirgendwo sonst verläuft. Eine Schleife ist der Identität äquivalent, wenn und nur wenn sie auf einen Punkt geschrunft werden kann.

Jede einfach zusammenhängende 3-dimensionale Mannigfaltigkeit, die keinen Rand hat und die nicht unendlich ist (der Begriff ist hier „kompakt“), ist eine dreidimensionale Sphäre.

Im 4-Raum gibt es unendlich viele nicht äquivalente differenzierbare Strukturen. Es gibt unendlich viele inkompatible Möglichkeiten der Infinitesimalrechnung im Vier-Raum. Das steht im Gegensatz zu allen anderen Dimensionalitäten: mit Ausnahme der Dimension vier gibt es für alle anderen nur eine differenzierbare Struktur auf dem Raum, der dem euklidischen Raum dieser Dimension zugrunde liegt.

Jede Oberfläche hat eine natürliche Geometrie, die eine hyperbolische ist. Jede hyperbolische Geometrie hat konstante negative Krümmung.

### **Poincare Vermutung für vier und mehr Dimensionen**

Milnor bewies fuer alle Dimensionen  $>$  grösser als 4 das Analogon der Poincare'schen Vermutung, d.h. für jede Dimension  $n$  grösser als vier ist eine einfach zusammenhängende,  $n$ -dimensionale Mannigfaltigkeit, die keinen Rand hat und nicht unendlich ist und diesselbe Homologie hat wie die  $n$ -dimensionale Sphäre, eine  $n$ -dimensional Sphäre.

Für  $n=4$  wurde es bewiesen von Michael Freedman (20 Jahre später): er konnte alle einfach zusammenhängenden, kompakten 4-dimensionalen Mannigfaltigkeiten charakterisieren.

### **Perelman's Lösungskonzept für die Dimension 4**

Arbeitet mit dem Ricci-Fluss, der sich von Gleichungen zur Temperaturverteilung in festen Körpern her ableitet, basierend auf der Quantifizierungsregel, dass Hitze von wärmeren in kältere Bereiche strömt. Im Fall von Krümmung ist der Ricci Tensor das Analogon der Wärmeleitungsgleichung, das spezifiziert, dass Mannigfaltigkeiten sich entsprechend der Temperaturverteilung entwickeln.

Given a Riemannian manifold with metric tensor  $g_{ij}$ , we can compute the Ricci tensor  $R_{ij}$ , which collects averages of sectional curvatures into a kind of "trace" of the Riemann curvature tensor. If we consider the metric tensor (and the associated Ricci tensor) to be

functions of a variable which is usually called "time" (but which may have nothing to do with any physical time), then the Ricci flow may be defined by the geometric evolution equation.

Informally, the Ricci flow tends to expand negatively curved regions of the manifold, and contract positively curved regions.

### Examples

- if the manifold is Euclidean space, or more generally Ricci-flat, then Ricci flow leaves the metric unchanged. Conversely, any metric unchanged by Ricci flow is Ricci-flat.
- if the manifold is a sphere (with the usual metric) then Ricci flow collapses the manifold to a point in finite time. If the sphere has radius 1 in  $n$  dimensions, then after time  $t$  the metric will be multiplied by  $(1 - 2t(n - 1))$ , so the manifold will collapse after time  $(1/2(n - 1))$ . More generally, if the manifold is an Einstein manifold (Ricci = constant  $\times$  metric), then Ricci flow will collapse it to a point if it has positive curvature, leave it invariant if it has zero curvature, and expand it if it has negative curvature.
- For a compact Einstein manifold, the metric is unchanged under normalized Ricci flow. Conversely, any metric unchanged by normalized Ricci flow is Einstein.

In particular, this shows that in general the Ricci flow cannot be continued for all time, but will produce singularities. For 3 dimensional manifold, Perelman showed how to continue past the singularities using surgery on the manifold.

- A significant 2-dimensional example is the cigar soliton solution which is given by the metric  $(dx^2 + dy^2)/(e^{4t} + x^2 + y^2)$  on the Euclidean plane. Although this metric shrinks under the Ricci flow, its geometry remains the same. Such solutions are called steady Ricci solutions. An example of a 3-dimensional steady Ricci soliton is the "Bryant solution", which is rotationally symmetric, has positive curvature, and is obtained by solving a system of ordinary differential equations.

### Relationship to uniformization and geometrization

The Ricci flow was introduced by Richard Hamilton in 1981 in order to gain insight into the geometrization conjecture of William Thurston, which concerns the topological classification of three-dimensional smooth manifolds. Hamilton's idea was to define a kind of nonlinear diffusion equation which would tend to smooth out irregularities in the metric. Then, by placing an arbitrary metric  $g$  on a given smooth manifold  $M$  and evolving the metric by the Ricci flow, the metric should approach a particularly nice metric, which might constitute a canonical form for  $M$ . Suitable canonical forms had already been identified by Thurston; the possibilities, called Thurston model geometries, include the three-sphere  $S^3$ , three-dimensional Euclidean space  $E^3$ , three-dimensional hyperbolic space  $H^3$ , which are homogenous and isotropic, and five slightly more exotic Riemannian manifolds, which are homogeneous but not isotropic. (This list is closely related to, but not identical with, the Bianchi classification of the three-dimensional real Lie algebras into nine classes.) Hamilton's idea was that these special metrics should behave like fixed points of the Ricci

flow, and that if, for a given manifold, globally only one Thurston geometry was admissible, this might even act like an attractor under the flow.

Hamilton succeeded in proving that any smooth closed three-manifold which admits a metric of positive Ricci curvature also admits a unique Thurston geometry, namely a spherical metric, which does indeed act like an attracting fixed point under the Ricci flow, renormalized to preserve volume. (Under the unrenormalized Ricci flow, the manifold collapses to a point in finite time.) This doesn't prove the full geometrization conjecture because the most difficult case turns out to concern manifolds with negative Ricci curvature and more specifically those with negative sectional curvature. (A strange and interesting fact is that all closed three-manifolds admit metrics with negative Ricci curvatures! This was proved by L. Zhiyong Gao and Shing-Tung Yau in 1986.) Indeed, a triumph of nineteenth century geometry was the proof of the uniformization theorem, the analogous topological classification of smooth two-manifolds, where Hamilton showed that the Ricci flow does indeed evolve a negative curved two-manifold into a two-dimensional multi-holed torus which is locally isometric to the hyperbolic plane. This topic is closely related to important topics in analysis, number theory, dynamical systems, mathematical physics, and even cosmology.

Note that the term "uniformization" correctly suggests a kind of smoothing away of irregularities in the geometry, while the term "geometrization" correctly suggests placing a geometry on a smooth manifold. Geometry is being used here in a precise manner akin to Klein's notion of geometry (see Geometrization conjecture for further details). In particular, the result of geometrization may be a geometry that is not isotropic. In most cases including the cases of constant curvature, the geometry is unique. An important theme in this area is the interplay between real and complex formulations. In particular, many discussions of uniformization speak of complex curves rather than real two-manifolds.

The Ricci flow does not preserve volume, so to be more careful in applying the Ricci flow to uniformization and geometrization one needs to normalize the Ricci flow to obtain a flow which preserves volume. If one fails to do this, the problem is that (for example) instead of evolving a given three-dimensional manifold into one of Thurston's canonical forms, we might just shrink its size.

It is possible to construct a kind of moduli space of  $n$ -dimensional Riemannian manifolds, and then the Ricci flow really does give a geometric flow (in the intuitive sense of particles flowing along flowlines) in this moduli space.

Man spezifiziert, dass sich die Temperatur in Richtung auf die Durchschnittstemperaturen auf einer kleinen Sphäre um den Punkt herum verändert: das nennt man Wärmeleitungsgleichung. Im Fall der Wärmeleitungsgleichung spezifiziert man, dass die Veränderungsrate der Temperatur im Hinblick auf die Zeit dem negativen Laplace-Operator proportional ist. Der Laplace-Operator mittelt die Grössen auf kleinen Sphären um einen Punkt herum: als eine Krümmung bezeichnet man den Mechanismus als Ricci-Fluss, der der Temperaturgleichung entspricht:

Um eine Analogie der Wärmeleitungsgleichung für die Krümmung zu generieren, muss man die unterschiedlichen Zahlen, die die Krümmung codieren, zu etwas kombinieren, das unabhängig von der Wahl der Koordinaten sinnvoll ist und eine Formel aufstellen, die die Veränderungsrate beschreibt. Wenn ein Gegenstand an verschiedenen Stellen unterschiedlich heiss ist, dann beginnen Energieströme zu fliessen, so lange, bis es überall

gleich warm ist. In ähnlicher Weise soll der Ricci-Fluss die Buckel und Dellen eines Drei-Dim-Körpers auf die Dauer ausgleichen, bis er einer von wenigen Standardformen gleicht. Unter anderem sollen so alle einfach zusammenhängenden Körper zu einer Sphäre werden. Das klappte in vielen Fällen (wie Hamilton gezeigt hat), nur manchmal bildeten sich Singularitäten, Punkte an denen die Dichte des Flusses plötzlich unendlich grosse Werte annimmt. Perelman zeigte eine Strategie, mit der man diese Singularitäten so behandeln kann, dass sie sich auf „gutartige“ Weise aus dem Körper herauschneiden lassen können und beantwortet damit auch die Poincare's Vermutung positiv.

Der Ricci-Tensor ist einer der wenigen Objekte, das von der Wahl der Koordinaten unabhängig ist. Man erhält ihn aus dem Riemann'schen Krümmungstensor, indem man unterschiedliche Kombinationen von Krümmungen in unterschiedlichen Richtungen mittelt.

Hamilton hat für 2-dim-Oberflächen u.a. gezeigt, dass der Ricci-Fluss schliesslich eine Metrik von konstant positiver Krümmung liefert. Irgendeine kompakte 2-dim. Oberfläche wird sich, wenn sich ihre Krümmung gemäss des Ricci-Flusses entwickelt, letztlich zu einer konstant gekrümmten Oberfläche entwickeln. Die Krümmung breitet sich aus, bis sie konstant wird. Dies ergab einen konzeptuellen Beweis, dass jede 2-dim. Mannigfaltigkeit eine einzigartige Geometrie trägt. Allerdings gilt im 3-dim. Fall, dass der Ricci-Fluss im allgemeinen zu Singularitäten führt, wenn die Zeit gegen unendlich geht.

Perelman zeigte, dass solche Regionen aber auf kontrollierbare Weise kollabieren und dies reicht aus, um daraus topologische Schlüsse zu ziehen. Der Parameter ist jetzt nicht mehr die Zeit, sondern die Skalierung und der Raum (Raum-Zeit-Kontinuum) wird nicht von einer Mannigfaltigkeit mit einer Metrik beschrieben, sondern von einer Hierarchie von Mannigfaltigkeiten und Metriken, die durch den Ricci-Fluss miteinander verbunden sind.

*„man beachte, dass wir hier ein Paradoxon haben: die bei einer grossen Entfernungsskala weit voneinander entfernt zu sein scheinen, können bei kleinerer Entfernungsskala einander näher kommen; wenn wir darüber hinaus den Ricci-Fluss durch Singularitäten zulassen können Regionen, die bei grosser Entfernungsskala in unterschiedlich zusammenhängenden Komponenten sind, zu Nachbarn werden ...“*

*„.... wie auch immer, dieser Zusammenhang zwischen Ricci-Fluss und dem Fluss der Renormierungsgruppe lässt darauf schliessen, dass der Ricci-Fluss einem Gradienten gleichen muss.“*

Perelman fand unerwartete Regelmässigkeiten, wenn die Krümmung so gross wurde, dass der Raum sich aufzulösen drohte, und er führte neue math. Methoden ein, um den potentiellen Zusammenbruch zu messen. Er zeigte, dass es einen Typ von Singularitäten überhaupt nicht geben konnte und dass andere sich auf sehr kontrollierte Weise verhielten: er zeigte die grundlegende geometrische Struktur des Ricci-Flusses in der Nähe von Singularitäten. Die Stellen im Fluss, an denen es Singularitäten gibt, sind Stücke, die aus der ursprünglichen Mannigfaltigkeit herausgeschnitten werden können und die homogene Geometrien im Sinne Thurstons haben. Nach dem Rausschneiden kann man den Ricci-Fluss neu starten und ihn laufen lassen, bis sich neue Singularitäten bilden und mit ihnen neue Regionen mit homogenen Geometrien. Dann diese Regionen wieder rausschneiden und den Fluss von neuem starten (→ eine enge Wechselwirkung von Geometrie und Topologie).

Der Ricci-Fluss ist eine Maschine, die die Mannigfaltigkeiten bearbeitet, sie streckt und formt und Stücke mit homogenen Geometrien abschneidet, um letztlich die gesamte Mannigfaltigkeit in homogene Abschnitte/Geometrien zu zerlegen.

Kochrezept: Starte mit einer Drei-Mannigfaltigkeit  $M$  ohne Rand, die endlos weitergeht und gib ihr mit Standardmethoden der Differentialtopologie eine geometrische Struktur. „Entwickle“ diese Mannigfaltigkeit mit dem Ricci-Fluss. Wenn diese Mannigfaltigkeit einfach zusammenhängend ist, dann glättet der Ricci-Fluss (nach ein paar harmlosen Operationen) die Extreme der Krümmung so, dass sich eine Mannigfaltigkeit mit konstant positiver Krümmung ergibt, die der ursprünglichen homöomorph ist. Das muss dann eine dreidimensional Sphäre sein, wie man seit langem weiss (→ mit ein paar Collapsing-Resultaten die Geometrisierung bewiesen!!!).

Poincaré's (Temperatur-) Modell des dreidimensionalen hyperbolischen Raumes kann man sich z.B. als eine in eine grosse Kugel eingeschlossene Welt denken, die folgenden Gesetzen unterworfen ist:

die Temperatur ist darin nicht gleichmässig verteilt; sie ist im Mittelpunkte am höchsten und vermindert sich in dem Masse, als man sich von ihm entfernt, um auf den absoluten Nullpunkt herabzusinken, wenn man die Kugel erreicht, in der die Welt eingeschlossen ist.

Man bestimmt das Gesetz, nach welchem diese Temperatur sich verändern soll, noch genauer. Sei  $R$  der Halbmesser der begrenzten Kugel, sei  $r$  die Entfernung des betrachteten Punktes vom Mittelpunkte dieser Kugel, dann soll die absolute Temperatur proportional zu  $R^2 - r^2$  sein. Man setzt weiter voraus, dass in dieser Welt alle Körper denselben Ausdehnungskoeffizienten haben, so dass die Länge irgendeines Line- als seiner absoluten Temperatur proportional sei.

Des weiteren setzt man voraus, dass ein Objekt, welches von einem Punkte nach einem mit verschiedenen Temperaturen übertragen wird, sich sofort ins Wärme-Gleichgewicht mit seiner neuen Umgebung setzt. Nichts ist dieser Hypothese widerspruchsvoll oder undenkbar.

Ein bewegliches Objekt wird also immer kleiner in dem Masse, wie es sich der begrenzenden Kugel nähert. Beachten wir vor allem, dass diese Welt ihren Einwohnern unbegrenzt erscheinen wird, wenn sie auch vom Gesichtspunkt unserer gewöhnlichen Geometrie aus als begrenzt gilt.

Wenn diese Einwohner sich in der Tat der begrenzten Kugel nähern wollen, kühlen sie ab und werden immer kleiner. Die Schritte, welche sie machen, sind also auch immer kleiner, so dass sie niemals die begrenzte Kugel erreichen können.

Wenn für uns die Geometrie nur das Studium der Gesetze ist, nach welchem die festen, unveränderlichen Körper sich bewegen, so wird sie für diese hypothetische Wesen das Studium der Gesetze sein, nach denen sich die (für jene Einwohner scheinbar festen) Körper bewegen, welche durch die soeben besprochenen Temperatur-Differenzen deformiert werden.

Ich werde noch eine andere Hypothese aufstellen: ich setze voraus, dass das Licht verschieden brechende Medien durchdringt, und zwar so, dass der Brechungsindex zu



$R^2 - r^2$  umgekehrt proportional sei. Es ist leicht zu ersehen, dass die Licht-Strahlen unter diesen Bedingungen nicht gradlinig, sondern kreisförmig sein werden...

Wenn diese hypothetischen Wesen eine Geometrie begründen, so wird diese nicht wie die unsrige das Studium der Bewegung unserer festen Körper sein; es wird vielmehr das Studium derjenigen Orts-Veränderungen sein, welche sie so von den übrigen unterschieden haben und welche keine anderen als die „nicht-euklidischen Ortsveränderungen“ sind, es wird die nicht-euklidische Geometrie sein.

So werden uns ähnliche Wesen, deren Erziehung in einer solchen Welt bewerkstelligt wäre, nicht dieselbe Geometrie wie wir haben.

## 17. Infinitesimals and Hyperreals

Do infinitesimals and even hyperreals “exist”? Is a “ir-rational” number  $\pi$  more “real” than a “hyper-real” number  $r + i$  ?

... perhaps only in the minds of certain mathematicians (but then with the same rational as  $\pi$  or complex numbers). Nevertheless, they are a fascinating concept. But first, a brief look at the history and structure of the real numbers. Today we think of this set as equivalent to the set of points of the real line - a sort of ruler extending endlessly in both directions from the point corresponding to zero. To the ancient Greeks, there were only points corresponding to rational numbers (ratios of whole numbers, e.g.,  $2/5$ ) and between any two points on a line there were only a finite number of such rational "points". When irrational numbers were discovered, they were deemed "incommensurable", meaning they could not be expressed as such ratios and, in a sense, were non-measurable.

As mathematical sophistication increased during the next two centuries, the ideas of Cauchy, Weierstrass and others took hold, and monads and moments - in their original guise - faded away. In the Standard Analysis that derived from their work, all real numbers were either rational or irrational, and "infinitesimal" came to mean simply very, very small, but real.

*There is an effective limit to the measurability of distances between points that are extremely close together. So, in a sense, there are "spaces" around points in which infinitesimals might reside. Perhaps aspects of logic break down, as they seem to in quantum mechanics, when dealing with microcosmic worlds.*

Rules for combining reals and non-traditional reals include:

(A) the sum of two infinitesimals is infinitesimal, as is the product;

(B) the product of a finite real number and an infinitesimal is an infinitesimal;

(C) the product of an infinitesimal and an infinite number may be finite or infinite, depending upon the numbers involved, etc. We can also write  $a \approx b$  ("a approximates b") if  $a - b$  is an infinitesimal. Hence, an infinitesimal  $\varepsilon \approx 0$ .

**Abraham (1966):** ". . . we observe that the non standard analysis is presented naturally, within the framework of contemporary mathematics, and thus appears to affirm the existence of all sorts of infinitely entities. . . . it appears to us today that the infinitely small and infinitely large numbers of a non-standard model of Analysis are neither more nor less real than, for example, the standard irrational numbers."

## 1. Diagonal paradoxon

A very old example related to the one given above, one that confounded mathematicians at the beginning of the 20th century - until they decided to ignore it - is the Diagonal Paradox :

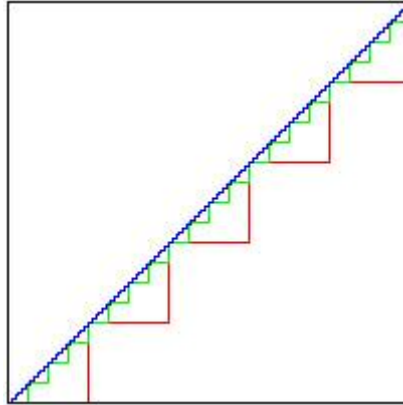

The large square is one unit on a side. The "stair steps" going from the bottom left corner to the top right corner contain  $n=5$ ,  $n=20$ , and  $n=110$  steps, respectively. The length of each such staircase curve is exactly 2 units. But as  $n$  becomes infinite, the polygonal curves approach a straight line: the diagonal of the large square, which is the square root of 2 (approximately 1.414) units long. Again, as we pass from the finite to the infinite, the result is a diagonal line of no thickness, 2 units long, trapped within an interval 1.414 units long, and sheathed in a halo of infinitesimal points.

$$\sqrt{2} = 1 + \frac{1}{2 + \frac{1}{2 + \frac{1}{2 + \frac{1}{2 + \dots}}}} = 1 + (2 + (2 + (2 + \dots)^{-1})^{-1})^{-1}$$

Due to a result from Lagrange we know, that a periodically structure is given only by the quadratic irrationals, i.e. real numbers of the form (Penrose 3.2).

$$a + \sqrt{b}$$

Vardi Ilan (Paris) has an interesting comment about this kind of paradox:

**Vardi Ilan:** "Regarding the notion of finite curves of infinite length, I have studied the works of Archimedes and I am fairly convinced that he had some notion of this possibility, because in his works he is very careful to set up axioms for length, in particular, his axiom that if two convex curves have the same endpoints and one is inside the other, then the inside one will be shorter. Otherwise, you do get problems."

## 2. Infinitesimals

There have been philosophical speculations about whether infinitesimals do actually correspond to points on a line (or in the complex plane). A point is dimensionless, so perhaps there are "positions" for both standard and non-standard real numbers on our ruler. After all, irrational numbers are never used in measurements by empirical scientists - all measurements are ultimately rational. One simple arithmetic operation involving the decimal forms of true irrational numbers would take an infinite amount of time to complete - even on the hypothetically best computers. It would take an eternity to even fully and completely describe the decimal forms. So, are the irrationals as abstract and strange as infinitesimals? Not quite, but there's more to them than one normally thinks.

Nowadays, we think of the real numbers as composed of both rationals and irrationals, "filling up" the real line. Between any two real numbers,  $a$  and  $b$ , are both a rational and an irrational, and, therefore, an infinite number of each in the interval  $[a,b]$ . Whereas the rationals can be shown to be "countable" (a discrete scheme for counting them can be devised), the irrationals are known to be "uncountable" (no such scheme can, in principle, exist).

A famous mathematician once compared the stars in the night sky to be like the rational numbers, and the blackness between them, the irrational numbers. Together they constitute the entirety of the numbers we use in the every-day world. In terms of familiar decimal representations, the rationals are all either terminating (e.g.,  $2/5 = .4$ ) or non-terminating but repeating (e.g.,  $3/11 = .27272727. . .$ ). Those decimal expansions that neither terminate nor repeat represent irrationals (e.g.,  $\pi = 3.14159.....$ )

### 3. Hyperreals

Let us call this new expanded real number system  ${}^*R$ . A function in  ${}^*R$  is a set (finite or infinite) of ordered pairs of numbers such that no two pairs have the same 1st element, but different 2nd elements. Note that in  ${}^*R$ , we might have, e.g.,

$$F = \{(1,7), (3,\pi), (\varepsilon, \infty), (\varepsilon + 1, \infty)\}$$

Assuming that  $x$  and  $a$  are in the domain of a bounded function  $G$  and that  $a$  is a standard real number, we can say that  $G$  is continuous at  $a$  provided  $G(a) \approx G(x)$  whenever  $x \approx a$ .

The area under a positive, continuous curve, given by  $f(x)$  on the interval  $[a,b]$ , can be defined as the infinite sum of areas of rectangles constructed by subdividing  $[a,b]$  into an infinite number of subintervals, each of which is of infinitesimal width, and height the value of  $f(x)$  for some  $x$  in that subinterval. This is similar to the definition of an integral given in a calculus course, except that the thin rectangles are now very thin indeed!

Suppose  $f(x)$  is a real valued function defined on the interval  $(a,b)$ , with  $a$  and  $b$  standard reals. Let  $\zeta$ , a standard real, be in the interior of  $(a,b)$ . Then the derivative of  $f(x)$  at  $x = \zeta$  may be expressed as

$$\frac{f(\zeta + \varepsilon) - f(\zeta)}{\varepsilon},$$

for all infinitesimals  $\varepsilon$ .

For example, let  $f(x) = x^2$ . Then

$$\frac{f(\zeta + \varepsilon) - f(\zeta)}{\varepsilon} = \frac{(\zeta + \varepsilon)^2 - \zeta^2}{\varepsilon} = \frac{2\varepsilon\zeta + \varepsilon^2}{\varepsilon} = 2\zeta + \varepsilon \approx 2\zeta$$

Summary and geometrical interpretation of Hyper-reals:

$({}^*R, +, *, \leq)$  ist ein angeordneter Körper mit  $R \subset {}^*R$  und  $R \neq {}^*R$ . Es sind  $+, *, \leq$  in  ${}^*R$  Fortsetzungen von  $+, *, \leq$  in  $R$ .  ${}^*R$  enthält unendliche Elemente und von Null verschiedene infinitesimale Elemente. Endliche Elemente von  ${}^*R$  sind infinitesimal benachbart zu einer reellen Zahl.

Ähnlich wie man sich  $R$  als Zahlengerade vorstellt, gibt es ein geometrisches Bild von  ${}^*R$ .  ${}^*R$  besteht aus endlichen und unendlichen Elementen. Da  ${}^*R$  total geordnet ist, ist ein unendliches Element entweder  $\leq 0$  oder  $\geq 0$ . Im ersten Fall liegt es dann links jeder negativen reellen Zahl, in zweiterem Fall recht jeder positiven reellen Zahl.  ${}^*R$  zerfällt damit in folgende drei disjunkte Bereiche: negativ unendliche Elemente, endliche Elemente, positiv unendliche Elemente. Der Bereich der endlichen Elemente von  ${}^*R$  zerfällt weiter in die disjunkten Bereiche der zu den verschiedenen reellen Zahlen infinitesimal benachbarten Elementen, in die sogenannten Monaden

$$m(r) := \{r \pm \varepsilon \mid 0 \leq \varepsilon \approx 0\}, r \in R.$$

Das ist eine sinnvolle Definition, weil zwei verschiedene reelle Zahlen nie infinitesimal benachbart sein können! Es ist, als ob sich der Punkt  $r \in R$ , wie durch ein Mikroskop mit unendlichem Auflösungsvermögen betrachtet, in  ${}^*R$  zu einer Monade  $m(r)$  vergrößert. Hierbei besitzt die Monade  $m(r)$  der unendlich nahe bei  $r$  liegenden Elemente kein kleinstes und kein grösstes Element, da mit  $\varepsilon \approx 0$  auch  $2\varepsilon \approx 0$  ist. Ferner enthält  $m(r)$  mit zwei Elementen auch sämtliches dazwischen liegende Element. Sind  $r_1, r_2$  zwei reelle Zahlen mit  $r_1 < r_2$ , so liegt die gesamte Monade  $m(r_1)$  links von der gesamten Monade  $m(r_2)$ . Da  $m(r)$  für jedes  $r \in R$  durch Verschiebung um  $r$  aus der Monade  $m(0)$  der infinitesimalen Elemente hervorgeht, bieten die Monaden bei der Betrachtung durch das Mikroskop alle dasselbe Bild.

Then, in the early 1960s, Abraham Robinson and others demonstrated that there exists a kind of extension of the real number system that includes non-traditional "real" elements: infinitesimals,  $\varepsilon$ , where  $|\varepsilon| < r$ , for all positive real numbers,  $r$ . Robinson showed that all the rules of arithmetic and algebra apply to this new, enlarged system, which includes, as well, numbers that are infinite. I.e., numbers of the form  $\omega$ , where for each such  $\omega$ ,  $|\omega| > n$  for all standard integers  $n$ . The normal rules for inequalities hold, so that  $\infty + 1 > \infty$ , and so on. It follows that  $1/\omega$  is an infinitesimal, and  $1/\varepsilon$  is infinite (except that division by 0 is not allowed). Robinson resurrects the word monad (of  $x$ ) to mean all real numbers infinitely close to  $x$ ; i.e., of the form  $x + \varepsilon$ . Other authors use pleasing terms like "mist" or "cloud" or "halo" to describe this concept.

Mathematicians who explore these strange worlds are frequently specialists in mathematical logic and set theory. And they have had some success at conceiving and describing infinitesimals and infinities in the context of Hyperreal Numbers. To the layman (even the non-specialist mathematician) often these results seem a bit contrived and don't coincide with intuition - but then intuition doesn't necessarily lead one to reality, whatever that is!

One way of constructing a system incorporating non-standard reals is to define "numbers" as infinite sequences of reals (or equivalence classes thereof). For example, let the number 3.27 be interpreted as  $(3.27, 3.27, 3.27, \dots)$  ad infinitum. Each real number is expressed as a constant, infinite sequence. Thus a "number"

$$(2^{-0}, 2^{-1}, 2^{-2}, 2^{-3}, 2^{-4}, \dots, 2^{-n}, \dots)$$

is non-real. If one further defines various operations and relations on these new numbers, corresponding to the operations and relations we are familiar with, it's possible to exhibit infinitesimals. E.g., define "<" to mean that for "most" terms of two sequences, this order exists between corresponding elements; then we have

$$(0, 0, 0, \dots, 0, \dots) < (2^{-0}, 2^{-1}, 2^{-2}, 2^{-3}, 2^{-4}, \dots, 2^{-n}, \dots) < (real, real, real, \dots, real, \dots)$$

for all positive reals - showing that the middle "number" is indeed "infinitesimal". There's much more to this, of course, and proper constructions require the use of *ultra filters* and other tools of set theory. But you get the idea.

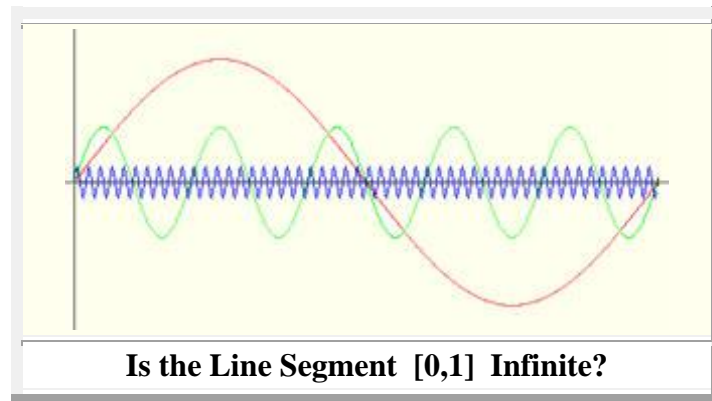

Consider the sequence of functions:

$$\{f_n(x)\} \quad \text{where} \quad f_n(x) := \frac{1}{10\sqrt{n}} \sin(n\pi x)$$

Each defined on  $[0,1]$ . The graphics above show functions with  $n = 2$ ,  $n = 10$ , and  $n = 100$ . It is easy to prove that the sequence converges uniformly to the straight line segment  $[0,1]$ . It is also straightforward to demonstrate that the length of each curve is

$$L_n(x) > \frac{\sqrt{n}}{5} \rightarrow \infty \quad \text{as} \quad n \rightarrow \infty$$

At any fixed degree of magnification, there is an  $n$  so large that the  $n$ th curve appears as a straight line. (Mathematicians routinely dismiss this sort of seeming paradox by simply citing "length" as a feature that is not preserved under uniform convergence.)

Note, that for each  $n$  the maximum distance of the curve from the line segment  $[0,1]$  is  $1/10\sqrt{n}$ . So for any positive real number  $r$  there is an  $n$  such that  $0 < 1/10\sqrt{n} < r$ . As we pass from the finite to the infinite, entering the strange world of  ${}^*\mathbb{R}$ , the resulting object is an infinite line of no thickness - trapped in the interval  $[0,1]$  and having a "cloud" of infinitesimal points cloaking it, above and below.

In the complex plane, infinitesimals may be of the form  $a + ib$ , or  $\langle a, b \rangle$ , where  $a$  and  $b$  are real infinitesimals. The "halo" or "complex monad" of a standard  $z$  becomes two dimensional.

#### 4. A valid Dirac FUNCTION

Die Nichtstandard-Analysis ermöglicht es, die Dirac-„Funktion“  $\delta: R \rightarrow R$ , die als solche nicht existiert, aber als lineares Funktional über einem geeigneten Raum stetiger Funktionen definiert werden kann, als Funktionen von  $R \rightarrow {}^*R$  einzuführen, die beliebig oft  $*$ -differenzierbar sind und die das  $*$ -Integral 1 besitzen:

**Definition:** ( $\delta$ -Funktionen als Abbildung von  $R \rightarrow {}^*R$ ) Eine Funktion  $\delta \in {}^*C(R)$  mit  $\delta \geq 0$  heisst  $\delta$ -Funktion, falls gilt:

$$\text{i) } \int {}^*\delta(x)dx = 1$$

$$\text{ii) } \int_{-\varepsilon}^{\varepsilon} {}^*\delta(x)dx \approx 1 \text{ für ein infinitesimales } \varepsilon > 0$$

**Lemma:** (Erzeugung von  $\delta$ -Funktionen aus stetigen Funktionen) Sei  $f \in C(R)$  mit  $f \geq 0$  und  $\int f(x)dx = 1$ . Dann gilt für jedes  $h \in {}^*N - N$ :

$$\delta(x) := hf(hx), \quad x \in {}^*R \text{ ist eine } \delta\text{-Funktion}$$

und es ist  $\delta \in {}^*C^{(k)}(R)$ , falls  $f \in C^{(k)}(R)$  ist für  $k \in N \cup \{\infty\}$ .

**Lemma:** (Zentrale Eigenschaft von  $\delta$ -Funktionen)

Sei  $\delta: R \rightarrow {}^*R$  eine  $\delta$ -Funktion und  $\varphi \in C_0^{(\infty)}(R)$ . Dann gilt:

$$\int {}^*\delta(x)\varphi(x)dx \approx \varphi(0).$$

Consider the Dirac Delta Function,  $\delta(x)$ , using  ${}^*R$ . This "function" is not really a function at all, and it can be described as a distribution in standard analysis, or as a measure, but roughly speaking,

$$\delta(x) = \begin{cases} 0 & \text{for } x \neq 0 \\ \infty & \text{for } x = 0 \end{cases} \quad \text{and} \quad \int_{-\infty}^{\infty} \delta(x)dx = 1$$

That is to say, the function is "so infinite" at  $x=0$  that the "area" it encompasses above the x-axis is exactly 1.



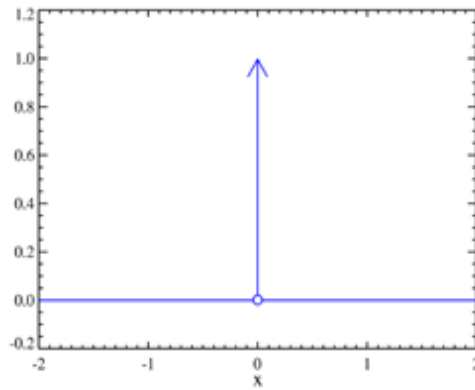

This is a "working function" used in physics and engineering, but it clearly makes little sense in  $\mathbb{R}$ , the standard reals. However, there is a simple and playful heuristic description in  $^*\mathbb{R}$  that is appealing:

$$\delta(x) = \begin{cases} 0 & \text{for } |x| > \varepsilon \\ \frac{1}{2\varepsilon} & \text{for } |x| \leq \varepsilon \end{cases} \quad \text{where } \varepsilon \text{ is some positive infinitesimal.}$$

The "area" under the curve, above the x-axis, is  $(\frac{1}{2\varepsilon})(2\varepsilon) = 1$ . Lots of luck, however, trying to visualize this rectangle with infinitesimal width and infinite height!

## 18. Hyperfunctions

We recall from [BPe] Petersen B.E., chapter 1, §15:

Let  $z \rightarrow g_z$  be a function defined on an open subset  $U \subset \mathbb{C}$  with values in the distribution space. Then  $g_z$  is called holomorphic in  $U \subset \mathbb{C}$  (or  $g(z) := g_z$  is called holomorphic in  $U \subset \mathbb{C}$  in the distribution sense), if for each  $\varphi \in C_c^\infty$  the function  $z \rightarrow (g_z, \varphi)$  is holomorphic in  $U \subset \mathbb{C}$  in the usual sense.

Hyperfunctions are distributions, allowing to treat “functions” by Fourier transform, which can transmit unexpected (non-analytic!) signals, represented by a Laurent-series description with vanishing constant “Fourier term” ([RPe] R. Penrose, 9.2). In the one-dimensional case hyper-functions are the distributions of the dual space  $C^{-\omega}$  of the real-analytical functions of a real variable  $C^\omega$ , defined on some connected segment  $\subset \mathbb{R}$  ([RPe] R. Penrose, 9.7, [ ] B. E. Petersen, 1.16) and appendix). This gives the link of our approach to Penrose’s thoughts and ideas moving forward “the road to reality”. In the one-dimensional case the concept of hyperfunctions enables a link between distributions and a holomorphic, i.e. a complex-analytical function, as any distribution  $f$  on  $\mathbb{R}$  can be realized as the “jump” of the corresponding in  $\mathbb{C} - \mathbb{R}$  holomorphic Cauchy integral function

$$F(x) := \frac{1}{2\pi i} \oint \frac{f(t) dt}{t - x}$$

across the real axis, given by

$$(f, \varphi) = \lim_{y \rightarrow 0^+} \int_{-\infty}^{\infty} (F(x+iy) - F(x-iy)) \varphi(x) dx \quad \text{for } y \rightarrow 0^+ .$$

The principle value  $P.v.(1/x)$  of the not locally integrable function  $1/x$  is the distribution  $g$  defined by ([BPe] B. E. Petersen, 1.7)

$$(g, \varphi) := \lim_{\varepsilon \rightarrow 0} \int_{|x| \geq \varepsilon} \varphi(x) \frac{dx}{x} = \int_{-\infty}^{\infty} \log|x| \varphi'(x) dx \quad \text{for each } \varphi \in C_c^\infty .$$

The relation of this specific principle value to the Fourier transform is given by ([BPe] B. E. Petersen, 2.9)

$$\left[ P.v.\left(\frac{1}{x}\right) \right]^\wedge = -i\pi \operatorname{sgn}(s) \quad \text{and} \quad \left[ P.v.\left(\frac{1}{x}\right) \right]^{\wedge\wedge} = -2\pi P.v.\left(\frac{1}{x}\right) .$$

In the one-dimensional case hyperfunctions are the distributions of the dual space  $C^{-\omega}$  of the real-analytical functions of a real variable  $C^\omega$ , defined on some connected segment  $\subset \mathbb{R}$ . Any real-analytical function is  $\in C^\infty$ , but not every function  $\in C^\infty$  is analytical, e.g. it holds

$$e(x) := \begin{cases} e^{-\frac{1}{x^2}} & x > 0 \\ 0 & x = 0 \end{cases} \in C^\infty \text{ but } e(x) \notin C^\omega .$$

From  $e^{(n)}(0) = 0$  for all  $n$  for the Taylor series it follows  $\sum_0^\infty \frac{0}{n!} x^n = 0$ , what's different to  $e(x)$

except at  $x = 0$ , i.e.  $e(x) \notin C^\omega$  is not an analytical function. The situation is different in case of complex-analytical functions, which are holomorphic and analytical at the same time.

In the one-dimensional case the concept of hyperfunctions (see e.g. [BPe] B. E. Petersen, 1.16) enables a link between distributions and a holomorphic, i.e. a complex-analytical function, as any distribution  $f$  on  $R$  can be realized as the "jump" of the corresponding in  $C - R$  holomorphic Cauchy integral function

$$\widehat{f}(x) := F(x) := \frac{1}{2\pi i} \oint \frac{f(t) dt}{t - x}$$

across the real axis, given by

$$(f, \varphi) = \lim_{y \rightarrow 0^+} \int_{-\infty}^{\infty} (F(x + iy) - F(x - iy)) \varphi(x) dx \quad \text{for } y \rightarrow 0^+ .$$

This means that the dual (distribution) space  $C^{-\omega}$  of the space of the real-analytical functions  $C^\omega$  characterizes the so-called hyperfunctions ([ ] R. Penrose, [ ] B. E. Petersen).

A hyperfunction of one variable  $f(x)$  on an open set  $\Omega \subset R$  is a formal expression of the form  $F_+(x + i0) - F_-(x - i0)$ , where  $F_\pm(z)$  is a function holomorphic on the upper, respectively lower, half-neighborhood  $U_\pm = U \cap \{z | \text{Im}(z) > 0\}$ , for a complex neighborhood  $U \supset \Omega$  satisfying  $\overline{U} \cap R = \Omega$ . The expression  $f(x)$  is identified with 0 if and only if  $F_\pm(z)$  agrees on  $\Omega$  as a holomorphic function.

If the limits exist in distribution sense, the formula gives the natural imbedding of the space of distributions into that of hyperfunctions. Hyperfunctions can be defined on real-analytic manifolds. Fourier series are typical examples of hyperfunctions on a manifold:

$$(*) \sum_{v \in Z} a_v e^{ivx} \text{ converges as a hyperfunction if and only if } a_v = O(e^{\varepsilon|v|}) \text{ for all } \varepsilon > 0.$$

Some examples of generalized functions interpreted as hyper functions are

a. Dirac's delta function  $\delta(x) = -\frac{1}{2\pi i} \left[ \frac{1}{x + i0} - \frac{1}{x - i0} \right] = \pi \lim_{a \rightarrow 0} \int_0^\infty e^{-ak} \cos kx dk , a \rightarrow 0$

b. Heaviside's function  $Y(x) = -\frac{1}{2\pi i} [\log(-x - i0) - \log(-x + i0)] = -\frac{1}{2\pi i} \log(-z) .$

The Heaviside function can be characterized ([BPe] B. E. Petersen, 1.16) by

$$\lim_{y \rightarrow 0^+} \log(x + iy) = \log x + i\pi \hat{Y} \quad \text{for } y \rightarrow 0^+ \quad \text{and} \quad \hat{Y}(x) = Y(-x)$$

c. 
$$x_{\pm}^{\lambda} = \frac{\pm (\mp z)^{\lambda}}{2i \sin \pi \lambda} \quad \text{for } \lambda \notin \mathbb{Z}$$

$$x_{\pm}^m = \pm \frac{1}{2\pi i} (\mp z)^m \ln(\mp z) \quad \text{for } \lambda = m \in \mathbb{Z}$$

d. the Feynmann propagator (Green's function) is the solution  $\frac{1}{2\pi i} (S^{\vee} - S^{\wedge})$

of the distribution wave equation

$$\left( \frac{\partial^2}{\partial t^2} - \Delta \right) S(t, x) = \delta(t) \delta^m(x)$$

with

$$2\pi(2\pi)^m S^{\wedge}(t, x) = \iint \frac{e^{-i\omega t + ikx} dk d\omega}{(\omega - |k| - i\varepsilon)(\omega - |k| - i\varepsilon)}$$

$$2\pi(2\pi)^m S^{\vee}(t, x) = \iint \frac{e^{-i\omega t + ikx} dk d\omega}{(\omega - |k| + i\varepsilon)(\omega - |k| + i\varepsilon)} \quad .$$

## 19. Hermitian Operator and Physical Observables

The spectrum of a hermitian, positive definite operator

$$A : D(A) \rightarrow H$$

with domain  $D(A)$  in a complex-valued Hilbert space  $H$  is discrete. This property enables an axiomatic building of the quantum mechanics, whereby, roughly speaking, physical states are modeled by the elements of the Hilbert space, observables of states by the operator  $A$  and the mean value of the observable  $A$  at the state  $\psi$  with  $\|\psi\|$  is given by

$$\langle A\psi, \psi \rangle .$$

In other words, the expectation value of an operator  $\hat{A}$  is given by

$$\langle A \rangle = \int \psi^*(\vec{r}) \hat{A} \psi(\vec{r}) d\vec{r}$$

and all physical observables are represented by such expectation values. Obviously, the value of a physical observable such as energy or density must be real, so it's required  $\langle A \rangle$  to be real. This means that it must be  $\langle A \rangle = \langle A \rangle^*$ , or

$$\langle A \rangle = \int \psi^*(\vec{r}) \hat{A} \psi(\vec{r}) d\vec{r} = \int [\hat{A} \psi(\vec{r})]^* \psi(\vec{r}) d\vec{r} = \langle A \rangle^*$$

Operators  $\hat{A}$ , which satisfy this condition are called *Hermitian*. One can also show that for a Hermitian operator,

$$\int \psi_1^*(\vec{r}) \hat{A} \psi_2(\vec{r}) d\vec{r} = \int [\hat{A} \psi_1(\vec{r})]^* \psi_2(\vec{r}) d\vec{r}$$

for any two states  $\psi_1$  and  $\psi_2$ .

For the eigenvalue problem of a self-adjoint, positive operator  $A$

$$A\varphi = \lambda\varphi$$

the eigenvalues  $\{\lambda\}$  are the discrete spectrum  $\lambda_n$  with either finite or countable infinite set of values

$$A\varphi_n = \lambda\varphi_n \quad , \quad \|\varphi_n\|^2 = 1$$

In this case the mean value of  $A$  is given by

$$\bar{A} := \langle \psi, A\psi \rangle .$$

Let  $w_n$  the probability, that the eigenvalue occurs of a measurement of the observables  $A$  then it holds for the mean value of  $A$

$$\bar{A} := \sum_n w_n \lambda_n = \sum_n w_n \langle \varphi_n, A \varphi_n \rangle \quad \varphi = \sum_n \alpha_n \varphi_n$$

$$\bar{A} := \langle \psi, A \psi \rangle = \left\langle \sum_n \alpha_n \varphi_n, A \left( \sum_n \alpha_n \varphi_n \right) \right\rangle = \sum_n \alpha_n^* \alpha_n \langle \varphi_n, A \varphi_n \rangle$$

$$\bar{A} := \langle \psi, A \psi \rangle = \sum_n \alpha_n^* \alpha_n \lambda_n \langle \varphi_n, \varphi_n \rangle = \sum_n |\alpha_n|^2 \lambda_n$$

i.e.  $w_n = |\alpha_n|^2 = \left| \langle \varphi_n, \varphi \rangle \right|^2$  .

The general solution of the Schrödinger equation is given by

$$\varphi(\vec{x}, t) = \sum_n c_n e^{-i\lambda_n \hbar t} \varphi_n(\vec{x}) .$$

In case the operator  $A$  is only hermitian (without being positive definite) Hilbert, von Neumann and Dirac developed a corresponding spectral theory. This leads to a continuous spectrum  $\lambda(\nu)$ , indexed by a continuous  $\nu$ . In this case  $\psi(x; \nu)$  denotes an eigen function to the eigen value  $\lambda(\nu)$ . The norm of this function is infinite, i.e. the function is not an element of the Hilbert space. An approximation to this function with finite norm is given (with sufficiently small  $\Delta \nu$ ) by the eigen differential

$$\Phi_{\Delta \nu}(x; \nu) = \frac{1}{\sqrt{\Delta \nu}} \int_{\nu - \Delta \nu / 2}^{\nu + \Delta \nu / 2} \phi(x; \nu') d\nu' .$$

All for the Hilbert space related properties are valid for the eigen differentials, but not for the eigen function itself. The scalar product of the eigen function is normed to a Dirac  $\delta$ -function:

$$\langle \phi(x; \nu'), \phi(x; \nu'') \rangle = \delta(\nu' - \nu'') .$$

The norm of the eigen differentials is given by:

$$\langle \Phi_{\Delta \nu}(x; \nu), \Phi_{\Delta \nu}(x; \nu') \rangle = \frac{1}{\Delta \nu} \int_{\nu - \Delta \nu / 2}^{\nu + \Delta \nu / 2} \int_{\nu' - \Delta \nu / 2}^{\nu' + \Delta \nu / 2} \langle \phi(x; \eta') d\nu' \phi(x; \eta'') \rangle d\eta' d\eta''$$

$$\langle \Phi_{\Delta \nu}(x; \nu), \Phi_{\Delta \nu}(x; \nu') \rangle = \frac{1}{\Delta \nu} \int_{\nu - \Delta \nu / 2}^{\nu + \Delta \nu / 2} \int_{\nu' - \Delta \nu / 2}^{\nu' + \Delta \nu / 2} \delta(\eta' - \eta'') d\eta' d\eta''$$

The integral is 1 for  $\nu = \nu'$  (with appropriate norm factor) and 0 if  $|\nu - \nu'| > \Delta \nu$ .

In case if  $\nu$  is a momentum the eigen differential gives a wave package with finite distance  $\Delta \nu$  in the momentum space and therefore with finite distance  $\Delta x \approx \frac{1}{\Delta \nu}$  in the particle space.

Such a package can normed to the value 1 (1 particle).  $\Delta x$  (and correspondingly  $\Delta \nu$ ) has to be larger than all other typical distances of the problem. In this sense eigen differentials correspond to the formalism of wave package modelling.

The eigen functions of the discrete and continuous spectrum build an extended Hilbert space to ensure that for every  $\psi$  it holds

$$\psi(x) = \sum_n c_n \phi_n(x) + \int c(\nu') \phi(x; \nu') d\nu'$$

with

$$c_n = \langle \phi_n(x), \psi(x) \rangle$$

and

$$c(\nu) = \langle \phi(x; \nu), \psi(x) \rangle$$

It holds the Parseval identity:

$$\langle \psi, \psi \rangle = \sum_n |c_n|^2 + \int |c(\nu')|^2 d\nu'$$

and the eigen differential are orthogonal wave packages.

If for every function  $\in L_2$  such a representation is possible, one call the system  $\{\phi\}$  a complete orthogonal system. Such a complete orthogonal system is not uniquely defined. There is always the degree of freedom

- to choose arbitrarily the phase of each eigen function
- the set of the non-standard eigenvalues can be orthogonalized on different ways
- to replace the index  $\nu$  of the continuous spectrum by an index  $\mu(\nu)$  with  $\mu(\nu)$  – differentiable, monotone function of  $\nu$ . Then

$$\phi(x; \mu) = \frac{\phi(x; \nu)}{\sqrt{d\mu/d\nu}}.$$

For not all hermitian operators there exist a complete orthogonal system of eigen functions. For all operators, which represent physical observables, there exist a complete orthogonal system.

## 20. Power Series

Functions analytic in a neighborhood of  $z = 0$ , can be expanded as power series (Taylor's Series) there:

$$F(z) = a_0 + a_1 z + a_2 z^2 + a_3 z^3 + \dots$$

with radius of convergence

$$|z| < R = \frac{1}{\limsup (a_n)^{1/n}}$$

Within the circle of convergence, the series converges uniformly to  $F(z)$ , and outside the circle, it diverges. The convergence behavior on the circumference of the circle varies with the function.

The following graphics show the regions of convergence of several functions, and how well the truncated series match the various functions, with darker hues indicating best approximations, and light hues, either divergence or poorer approximations.

### Example 1

$$F(z) = \frac{1}{1-z} = 1 + z + z^2 + z^3 + \dots \quad |z| < 1$$

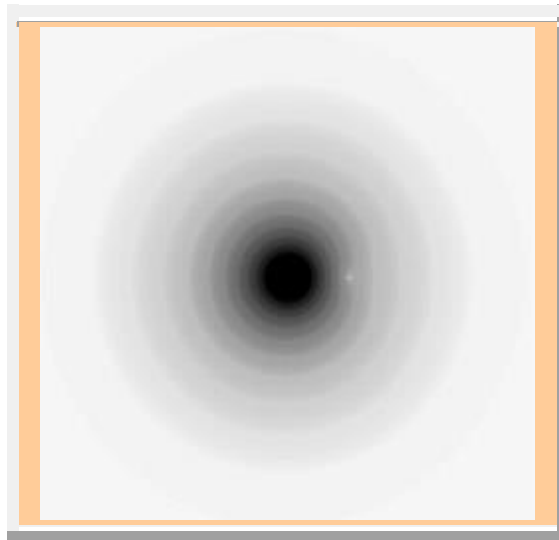

$n = 10$  and Image radius 4



## Example 2

$$F(z) = \ln \frac{1}{1-z} = z + \frac{z^2}{2} + \frac{z^3}{3} + \dots + \frac{z^n}{n} + \dots \quad |z| < 1$$

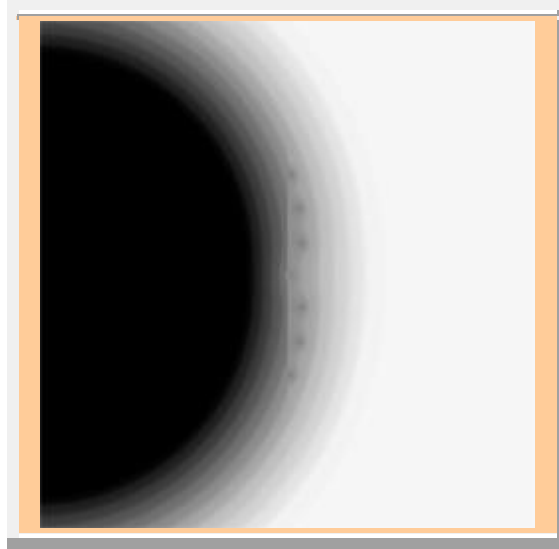

$n = 50$  Center of Image:  $1+0i$  Image radius 1  
Dark points are anomalies slightly outside circle of convergence,  
showing better approximations than expected.

### Example 3

$$F(z) = \cos(z) = 1 - \frac{z^2}{2!} + \frac{z^4}{4!} - \dots + (-1)^n \frac{z^{2n}}{(2n)!} + \dots \quad |z| < \infty$$

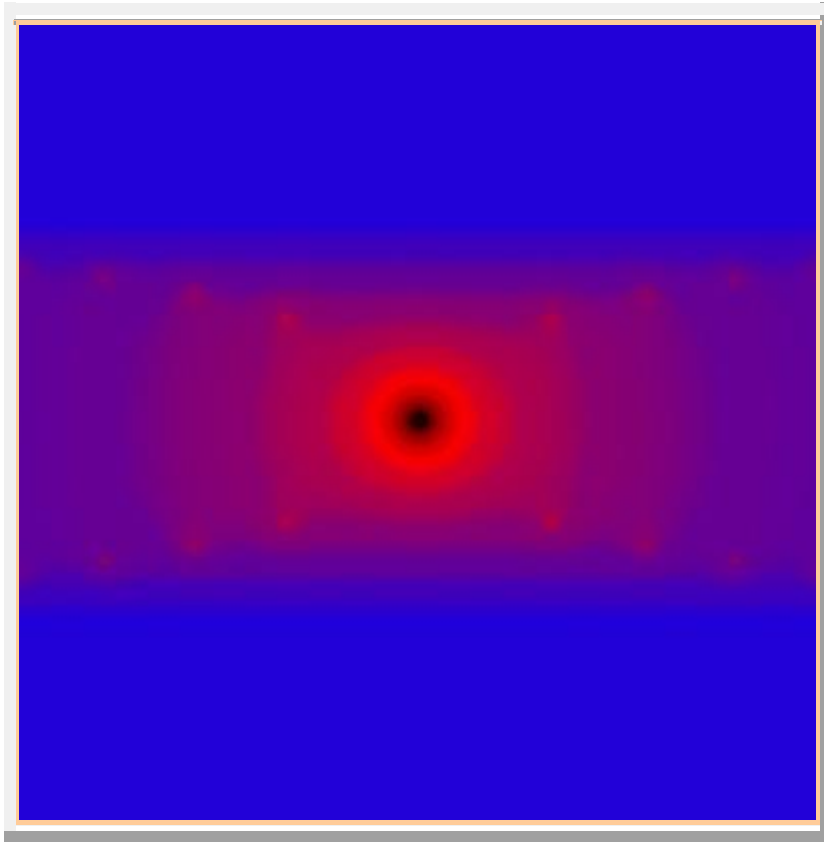

$n = 5$  (Polynomial of degree 10) Image Radius 30; Red spots indicate better approximations than usual for that radius - blue shows poorer approximations

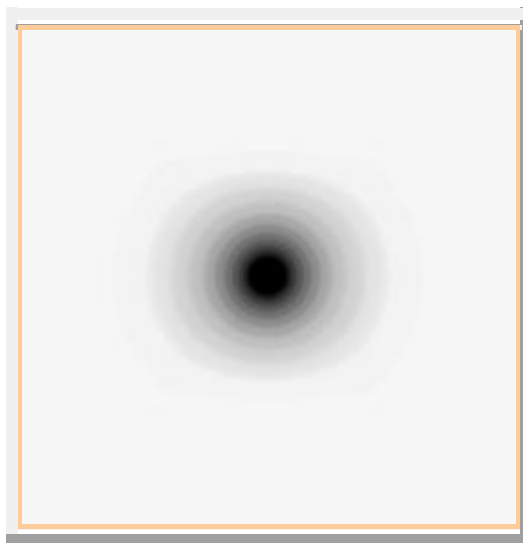

$n = 10$  (Polynomial of degree 20) Image Radius 30

## 21. Continued Fractions - Analytic Theory

Continued Fractions are algebraic constructions of the form

$$\frac{a_1}{b_1 + \frac{a_2}{b_2 + \frac{a_3}{b_3 + \dots}}}$$

If this process does not terminate, the CF is said to be infinite, in the same way a non-terminating series is said to be infinite. If the  $a_n(z)$  and  $b_n(z)$  are functions of a complex variable,  $z$ , and  $\omega$  is another such variable, we have

$$F_n(z; \omega) = \frac{a_1(z)}{b_1(z) + \frac{a_2(z)}{b_2(z) + \frac{a_3(z)}{b_3(z) + \dots + \frac{a_n(z)}{b_n(z) + \omega}}}}$$

Called the normal  $n$ th convergent of the infinite CF when  $\omega = 0$ . Simpler notational formats include the following:

$$F_n(z; \omega) = \frac{a_1(z)}{b_1(z) + \frac{a_2(z)}{b_2(z) + \frac{a_3(z)}{b_3(z) + \dots + \frac{a_n(z)}{b_n(z) + \omega}}}}$$

It is possible to expand complex functions as continued fractions using a number of distinct algorithms. This variety of expansion formats, plus a bewildering assortment of convergence theorems, contrasts strongly with the relative simplicity of power series expansions and their convergence criteria. Why then bother with CFs? Two reasons: (1) frequently CF expansions converge more rapidly than the series (although not always), and, (2) CF expansions may be valid in a much larger domain than power series. As a simple - even trivial - example,

$$F(z) = 1 + z + z^2 + z^3 + \dots = \frac{1}{1-z}$$

The series on the left converges in a disc about the origin of radius 1. It diverges outside this disc. The expression on the right is, in fact, a finite CF, converging instantly for all values of  $z$  with the exception of  $z = 1$ .

We begin with graphics, looking at a convergent of the periodic CF,

$$F_n(z) = \frac{z}{1 + \frac{z}{1 + \frac{z}{1 + \dots + \frac{z}{1 + z}}}}$$

Going down to the nth level. This convergent is a rational function of degree n, having both fixed points and poles. Here we see how the nth convergent displaces points in the z-plane, with little or no displacement = dark and high displacement = light:

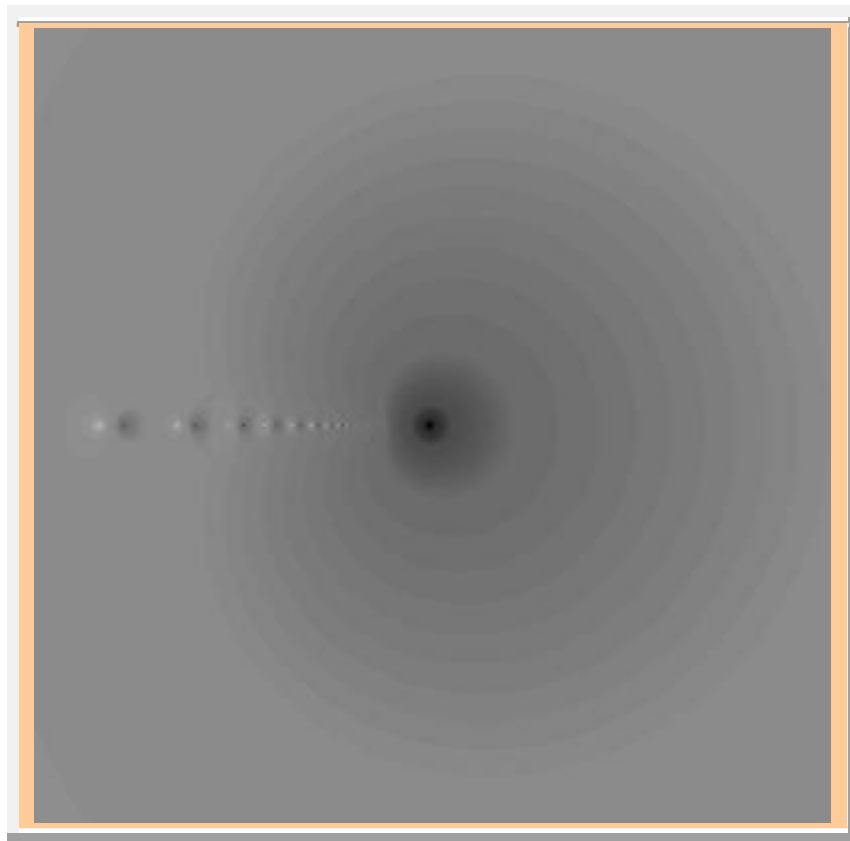

The point  $z=0$  is, of course, a fixed point ( $F(z)=z$ ). The graph of the 50th convergent shows a series of alternating poles and what appear to be fixed points along the negative real axis (a portion of which is actually the branch line for the single valued function of which this is a CF expansion). The image is centered at  $z=0$  and extends 2 units to the right and left.

Next, we expand the function  $F(z) = \text{p.v. } \sqrt{z}$ , about  $z=0$ , obtaining another periodic CF:

$$\sqrt{z}-1 = \frac{z-1}{1+\sqrt{z}} \Rightarrow \sqrt{z} = 1 + \frac{z-1}{2 + \frac{z-1}{2 + \frac{z-1}{2 + \dots + \frac{z-1}{2 + \frac{z-1}{2 + \dots}}}}}$$

Comparing graphically the 10th convergent with the value of the function  $F(z)$ , we have the following, where darkest hues indicate strong approximations ( $< 10^{-5}$ ), and light hues, poor approximations:

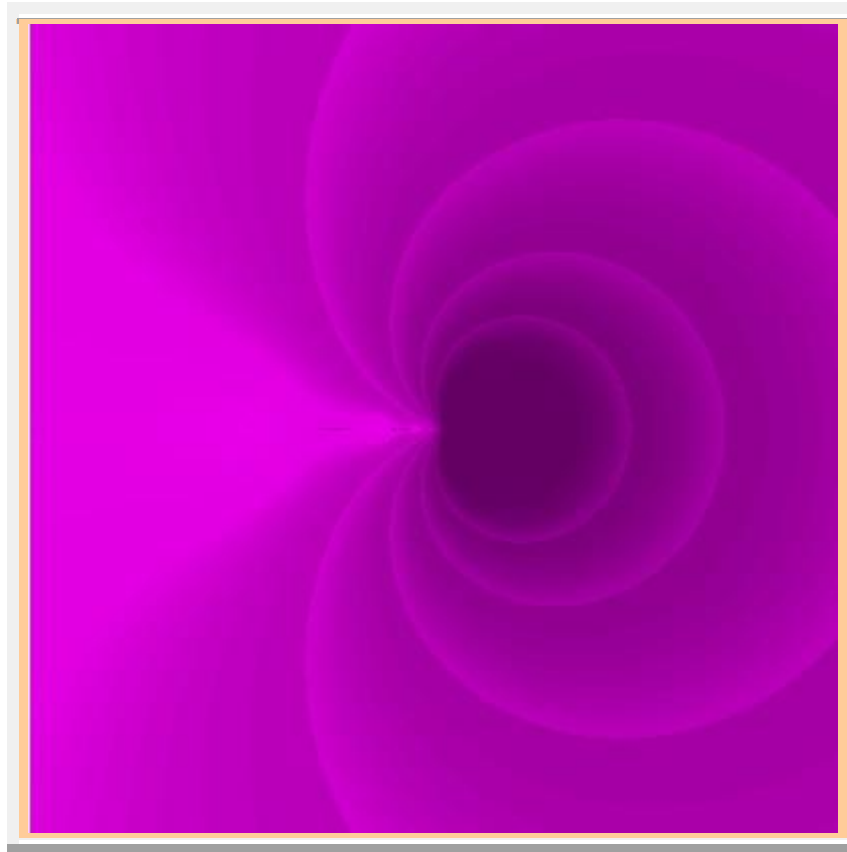

The graph is centered at the origin, extending 10 units to the right and left. The branch line of the function extends from the origin along the negative real axis. Poles of the rational approximation appear faintly as light spots along the branch line.

## 22. Analytic Theory of Continued Fractions

As an example of expansion into a CF of an analytic function, consider:  $F(z) = \arctan(z)$  . From Continued Fractions: Analytic Theory and Applications, by W. Jones and W. Thron (1980), we have the following (written using a common format for CFs):

$$\arctan(z) = \frac{z}{1 + \frac{1^2 z^2}{3 + \frac{2^2 z^2}{5 + \frac{3^2 z^2}{7 + \dots}}}}$$

Valid nearly everywhere in the complex plane as the single-valued branch of the analytic function with branch points at  $z = i$  and  $z = -i$  and branch lines north of  $i$  , and south of  $-i$  .

To compute  $\pi/4 = \arctan(1)$  to seven decimal places requires merely going out to the 9th convergent of the CF. Whereas, using the standard power series expansion:

$$\arctan(z) = z - \frac{z^3}{3} + \frac{z^5}{5} - \frac{z^7}{7} + \dots \quad |z| \leq 1 \quad z \neq i, -i$$

Valid only within the unit disc, one needs to employ (approximately) the first 500,000 terms of the series. Thus this example demonstrates the two previously stated reasons for using Cfs as functional expansions: greater speed of convergence and enhanced region of convergence.

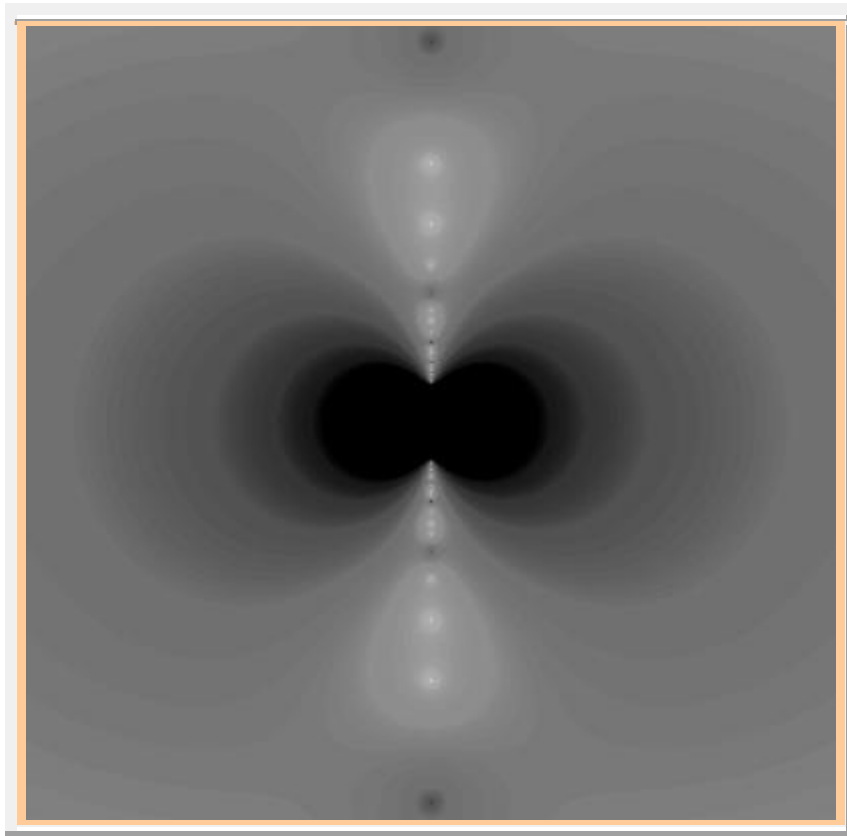

The speed of convergence of the CF expansion of  $\text{Arctan}(z)$ , showing results for the 15th convergent vs the 30th convergent. Graph is centered at the origin, extending 10 units right and left ; branch lines above  $z = i$  and below  $z = -i$  are clearly shown. The convergent is, of course, a rational function approximation to the Arctangent, and poles are illuminated along the branch lines. Dark areas indicate rapid convergence of the CF.

A CF expansion of the function  $F(z) = -\ln(1-z)$

$$F(z) = -\ln(1-z) = \frac{z}{1-} \frac{1^2 z}{2-} \frac{1^2 z}{3-} \frac{2^2 z}{4-} \frac{2^2 z}{5-} \frac{3^2 z}{6-} \frac{3^2 z}{7-}$$

converges and represents a single-valued branch of the function in the complex plane, with branch cut along the real axis to the right of  $z=1$ . The speed of convergence is displayed in the following graphic, where we compare the 10th convergent to the 30th. As usual, dark = rapid, light = slow. Since any convergent is merely a rational approximation to the function, poles are seen illuminated along the branch cut. The scope of the figure is  $|x|, |y| < 10$ .

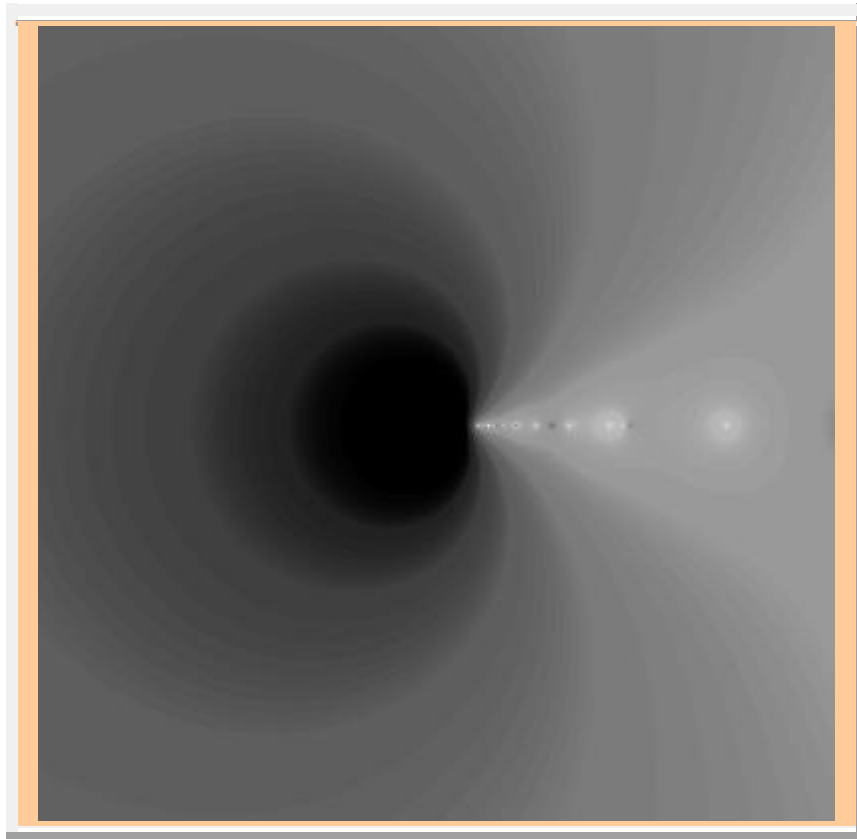

As we have seen before, the power series expansion of this function about  $z=1$  fails to even converge outside of the unit disc.

## 23. Monadentheorie

Leibniz entwickelte die Monadentheorie als Gegenentwurf zu den zeitgenössischen Strömungen. Die Philosophen des 17. Jahrhunderts arbeiteten in der Regel entweder eine neue Substanztheorie aus oder sie entwickelten die Atomtheorie nach neuzeitlichen Maßstäben weiter. Leibniz befriedigte keine dieser Auffassungen. Er nennt die Philosophie der Atomisten eine „faule“ Philosophie, da diese Auffassung, welche die Atome als letzte Bausteine ansieht, die lebendige, sich verändernde Welt nicht tiefgründig genug analysiere. Entgegen atomistischer Zeit- und Raumauffassungen, die diese Existenzformen der Materie mit einem leeren Gefäß vergleichen, vertritt Leibniz eine dialektische Konzeption, in der Raum und Zeit Ordnungsbeziehungen in der materiellen Welt sind. Der Raum ist die Ordnung der zur gleichen Zeit existierenden Dinge, die Zeit die Ordnung ihrer kontinuierlichen Veränderungen.

Den Monadenbegriff greift er aus der neuplatonischen Tradition auf. Der Begriff Monade, „Einheit“, stammt aus der *Stoicheiosis theologike* des spätantiken Philosophen Proklos. Wenn man die unendliche Substanz Baruch de Spinozas und des Mathematikers Blaise Pascal in unzähligen Punkten repräsentiert findet, deren jeder das Universum enthält, dann hat man ein Bild für das Bewusstsein, das in seinem Ichpunkt das ganze All umfasst: dann hat man die Leibnizschen Monaden.

Eine Monade – der zentrale Begriff der Leibnizschen Welterklärung – ist eine einfache, nicht ausgedehnte und daher unteilbare Substanz, die äußeren mechanischen Einwirkungen unzugänglich ist.

Das gesamte Universum bildet sich in den von den Monaden spontan gebildeten Wahrnehmungen (Perzeptionen) ab. Sie sind eine Art spirituelle Atome, ewig, unzerlegbar, einzigartig. Die Idee der Monade löst das Problem der Wechselwirkung von Geist und Materie, welches dem System René Descartes' entspringt. Ebenso löst sie das Problem der Vereinzelung, welches im System Baruch Spinozas problematisch erscheint. Dort werden einzelne Lebewesen als bloß zufällige Veränderungen der einzigen Substanz beschrieben. Ein Beispiel: Eine Substanz kann ohne Denken existieren, aber das Denken nicht ohne Substanz.

Da Leibniz die Grundfrage der Philosophie idealistisch löst und die Materie für ihn nur ein „Anderssein der Seele“ ist, verwirft er den absoluten Charakter von Raum und Zeit. Raum und Zeit werden in der Leibnizschen Metaphysik als Ordnungsbeziehungen zwischen Entitäten der materiellen Welt verstanden. Die Theorie der Substanz von Leibniz schließt die Möglichkeiten der allseitigen Entwicklungen ein. Obwohl die Monaden in ihren Keimen identisch sind, entwickeln sie sich verschieden. Entwicklung bedeutet nach Leibniz nicht das Entstehen von grundsätzlich Neuem, sondern nur die Entfaltung des Vorhandenen. Leib, Seele und Geist sind nicht grundsätzlich verschieden, sie sind bloß unterschiedlich entwickelt. Leibniz löst das Problem der Verbindung von Körper und Seele, indem er darlegt, dass alle Monaden, obwohl sie keinen gegenseitigen Einfluss auf ihre innere Struktur ausüben, koordiniert wirken. Er behauptet, dass Gott beim Schaffen der Monaden ihre Einheit und koordinierte Wirkung gesichert habe. Er kennzeichnet diesen Zustand mit dem Begriff der „prästabilierten Harmonie“. Trotz des idealistisch-teleologischen Wesens dieser Anschauung ist das Bemühen zu spüren, die Einheit der Welt nachzuweisen und die in ihr wirkenden Gesetzmäßigkeiten aufzudecken.



## 24. Black-body radiation

A famous usage of Dirichlet's series is in the context of Planck's black-body radiation function

$$\frac{dR(\lambda, T)}{d\lambda} = \frac{c_1}{\lambda^5} \frac{1}{e^{c_2/\lambda T} - 1} = \frac{c_1}{\lambda^5} \sum_1^{\infty} e^{-nc_2/\lambda T}$$

with  $c_1 = 2\pi^5 hc^2$  and  $c_2 = hc/k$ . The relation to the Zeta function

$$\zeta(s)\Gamma(s) = \int_0^{+\infty} \frac{x^s}{e^x - 1} \frac{dx}{x}$$

is given by

$$\frac{\pi^4}{90} = \zeta(4)\Gamma(4) = \int_0^{+\infty} x^4 \left( \sum_1^{\infty} e^{-nx} \right) \frac{dx}{x} = \int_0^{+\infty} x^{-4} \left( \sum_1^{\infty} e^{-\frac{n}{x}} \right) \frac{dx}{x} .$$

This describes the total radiation and its spectral density at the same time, i.e.

$$g(x)dx = \frac{x^{-4}}{e^{1/x} - 1} \frac{dx}{x} = \frac{x^4}{e^x - 1} \frac{dx}{x} = g\left(\frac{1}{x}\right)dx .$$

The weak formulation (and the positive Berry conjecture answer) should enable an alternative model for the total radiation and its spectral density.

## 25. Wavelets

A wavelet transform is similar as a Fourier transform, which delivers the frequency spectrum of a timely signal  $f(t)$  without any loss of information, although the Fourier transform itself gives the frequencies without any information about the points in time, when the frequencies occur. The wavelet transform delivers this sort of information in a better distinguishing form: one gets both the frequency analysis and the points in time, when those frequencies happen, similar like the written notes, which results into the music of an orchestra, which are described in form of a wavelet transform on a 2-dimensional paper ([23] M. du Sautoy: "the primes have music in them")

A wavelet is a function  $\psi(x) \in L_2(\mathbb{R})$  with a Fourier transform which fulfills

$$0 < c_\psi := 2\pi \int_{-\infty}^{\infty} \frac{|\hat{\psi}(\omega)|^2}{|\omega|} d\omega < \infty .$$

The wavelet transform of a function  $f(x) \in L_2(\mathbb{R})$  with the wavelet  $\psi(x) \in L_2(\mathbb{R})$  is the function

$$W_\psi[f](a, b) := \frac{1}{\sqrt{c_\psi}} \int_{-\infty}^{\infty} f(t) \bar{\psi}_{b,a}(t) dt = \frac{1}{\sqrt{c_\psi}} \int_{-\infty}^{\infty} f(t) \frac{1}{\sqrt{a}} \bar{\psi}\left(\frac{t-b}{a}\right) dt, \quad a \in \mathbb{R} - \{0\}, b \in \mathbb{R}$$

For a wavelet  $\psi(x) \in L_1(\mathbb{R})$  its Fourier transform is continuous and fulfills

$$0 = \hat{\psi}(0) = \frac{1}{2\pi} \int_{-\infty}^{\infty} \psi(t) d\omega$$

The wavelet transform to the wavelet  $\psi(x) \in L_2(\mathbb{R})$

$$W_\psi : L_2(\mathbb{R}) \rightarrow L_2(\mathbb{R}^2, \frac{dadb}{a^2}),$$

is isometric and for the adjoint operator

$$W_\psi^* : L_2(\mathbb{R}^2, \frac{dadb}{a^2}) \rightarrow L_2(\mathbb{R})$$

$$W_\psi^*[g](a, b) := \frac{1}{\sqrt{c_\psi}} \int_{-\infty}^{\infty} \int_{-\infty}^{\infty} g(t) \frac{1}{\sqrt{a}} \psi\left(\frac{t-b}{a}\right) g(a, b) \frac{dadb}{a^2}$$

it holds  $W_\psi^* W_\psi = Id$  and  $W_\psi W_\psi^* = P_{\text{range}(W_\psi)}$ .

The continuous wavelet transform is known in pure mathematics as Calderón's reproducing formula, i.e. for  $\psi(x) \in L_1(\mathbb{R}^n)$  real and radial with vanishing mean, i.e.

$$\int_0^{\infty} \frac{|\hat{\psi}(a\omega)|^2}{a} da \equiv 1$$

It holds for  $\psi_a(x) := \frac{1}{a^n} \psi\left(\frac{x}{a}\right)$  Calderón's formula, i.e.

$$f = \int_0^\infty \psi_a * \psi_a * f \frac{da}{a} .$$

Classical Hilbert spaces in complex analysis are examples of wavelets, like Hardy space of  $L_2$  functions on the unit circle with analytical continuation inside the unit disk.

We note that  $\varphi'(x^2)$  has a similar structure than the Mexican hat, which is a continuous wavelet function (see remark 1.16 below)  $\psi(x) = -\frac{d^2}{dx^2} e^{-x^2/2} = (1-x^2)e^{-x^2/2} \in L_2(\mathbb{R})$  fulfilling

$$0 < c_\psi := 2\pi \int_{-\infty}^{\infty} \frac{|\hat{\psi}(\omega)|^2}{|\omega|} d\omega < \infty .$$

## References

- [Bi] Bishop R., Goldberg S., Tensor Analysis on manifolds, Dover Publications, Inc., New York, 1980
- [CoHi] Courant R., Hilbert D., Methoden der Mathematischen Physik, I, II, Springer-Verlag Berlin, Heidelberg, New York, 1968
- [Fi] Fischer K., Gottfried Wilhelm Leibniz, Leben, Werke und Lehre, Thomas Sören Hoffmann, marixverlag, Wiesbaden, 2009
- [Gr] Green M.B., Schwarz J.H., Witten E., Superstring theory, Cambridge University Press, 1987
- [Fi1] Fichera G., Linear elliptic differential systems and eigenvalue problems, Springer Verlag, Berlin, Heidelberg, New York, 1965
- [Fi2] Fichera G., Existence theorems in elasticity-boundary value problems of elasticity with unilateral constraints, Encyclopedia of physics, vol Via/2: mechanics of solids II, pp. 347-424, Springer Verlag, Berlin, 1972
- [FrK] Friedrichs K.O., On the boundary value problems of the theory of elasticity and Korn's inequality, Ann. Math., 48, 441-471, 1947
- [KaM] Kaku M., Introduction to Superstrings and M-Theory, Springer-Verlag, New York, 1984
- [KaY] Kato Y., On the coerciveness for integro-differential quadratic forms, J. Analyse Math., 27 (1974), 118-158. Department of Engineering Mathematics Faculty of Engineering Nagoya University
- [Ko] Korn A., Ueber einige Ungleichungen, welche in der Theorie der eleastischen und elektrischen Schwingungen ene rolle spielen, Bull. Intern. Cracov. Akad. Umiejet (Classe Sci. Math. Nat.) pp. 706-724, 1909
- [LaC] Lanczos C., The variational principles of mechanics, Dover Publications, Inc. New York, fourth edition, 1949, 1962, 1966, 1970
- [LaL] Landau L.D., Lifschitz E.M., Lehrbuch der theoretischen Physik II, Klassische Feldtheorie, Akademie Verlag Berlin, 7. Auflage, 1977
- [Mi] P. Mittelstaedt, Philosophische Probleme der modernen Physik, BI Hochschultaschenbücher, Mannheim, wien, Zürich, 1989
- [Pa] Payne L.E. Weinberger H.F., On Korn's inequality, Arch. Rational Mech. Anal. 8, pp. 89-98, 1961
- [PeR] Penrose R., The Road to Reality, Alfred A. Knopf, New York, 2005
- [PeB] Petersen B.E., Introduction to the Fourier Transform & Pseudo-differential Operators,
- [Pi] H. Pitman Publishing Limited, Boston, London, Melbourne
- [Ro] A. Robinson, Non-standard analysis, Proc. Roy. Acad. Amsterdam Ser. A 64, 432-440, 1961] H. Pitman Publishing Limited, Boston, London, Melbourne

[Sc] Schrödinger E., Die Struktur der Raum-Zeit (Space-time structure), Wissenschaftliche Buchgesellschaft, Darmstadt, 1987

[StE] Stein E.M., Singular integrals and Differentiability Properties of Functions, Princeton University Press, Princeton, 1970

[StI] I. Strohmeyer, quantentheorie und Transzendentalphilosophie, Spektrum Akademischer Verlag, Heidelberg, Berlin, Oxford, 1995

[StR] Strichartz R.S., A Guide to Distribution Theory and Fourier Transforms, World Scientific, New Jersey, London, Singapore, Hongkong, reprinted 2008

[Ve] Velte W., Direkte Methoden der Variationsrechnung, Teubner Studienbücher, 1976

### **Some additional references**

J.B. Hartle, S.W. Hawking, Wave function of the universe, The Amer. Physical soc., Physical Review D, Vol 28, No 12, 1983, pp. 2960-2975

C.J. Hogan, Auf der Suche nach dem Quanten-Ursprung der Zeit, Spektrum der Wissenschaft, Dossier 01/03, Vom Quant zum Kosmos

D.Z. Albert, David Bohms Quantentheorie, Spektrum der Wissenschaften, Juli 1994

L. Nottale, The theory of scale relativity

N. Lascin, Fractal Quantum Mechanics

J.-F. Burnol, Causality in the study of the Hankel transform

A. Sitaram, The uncertainty principle: a mathematical survey, The Journal of Fourier Analysis and Applications, Vol 3, No 3, 1997, pp. 207-308

G. Landsberg, Ueber die Totalkruemmung, pp. 36-46, [digizeitschriften@sub.uni-goettingen.de](mailto:digizeitschriften@sub.uni-goettingen.de)

H. Minkowski, Die Grundgleichungen für die elektromagnetischen Vorgänge in bewegten Körpern, pp.472-525, [digizeitschriften@sub.uni-goettingen.de](mailto:digizeitschriften@sub.uni-goettingen.de)

M. Born, Eine Ableitung der Grundgleichungen für die elektromagnetischen Vorgänge in bewegten Körpern vom Standpunkt der Elektronentheorie, [digizeitschriften@sub.uni-goettingen.de](mailto:digizeitschriften@sub.uni-goettingen.de)

A. Anzenbacher, Einführung in die Philosophie, Herder Verlag, Wien, Freiburg, Basel, 1981

F. Geschwind, Pseudodifferential Operators on SU(2), The Journal of Fourier Analysis and Applications, Vol 3, No 2, 1997, pp. 193-206

- E.I. Gordon, Fourier transform in nonstandard analysis, *Izvestiya VUZ, Matematika*, Vol 33, No 2, pp. 17-25, 1989
- D. Laugwitz, eine Einführung in die Delta-Funktionen, *Bayer. Akad. Wiss. Math.-Nat. Kl. S.-B.*, 41-59, 1959
- G.W. Leibniz, *Monadologie*, Philipp Reclam Jun., Stuttgart
- G. Deleuze, *Le phil. Leibniz et le baroque*, Les éditions de Minuit, Paris, 1988 (Die Falte: Leibniz und der Barock, Suhrkamp, Frankfurt a.M., 1995)
- D.R. Hofstadter, *I Am a Strange Loop*, Basic Books (Perseus Books Group), New York, 2007 (Ich bin eine seltsame Schleife, J.G. Cotta'sche Buchhandlung Nachfolger GmbH, Stuttgart, 2008)
- I. Agricola, Th. Friedrich, *Globale Analysis*, vieweg Verlag, Braunschweig, Wiesbaden, 2001
- B. Mandelbrot, *Die fraktale Geometrie der Natur*, Berlin, Akademie, 1987
- Davis, Martin D., *Applied Nonstandard Analysis*, New York, NY: John Wiley, 1977.
- Hurd, Albert E. and Loeb, Peter A., *An Introduction to Nonstandard Real Analysis*, New York, NY: Academic Press, 1985.
- Robinson, Abraham, *Non-standard Analysis*, Amsterdam: North-Holland, 1966.
- Stroyan, K.D. and Luxemburg, W.A.J., *Introduction to the Theory of Infinitesimals*, New York, NY: Academic Press, 1976.
- E. Gordon, *Nonstandard methods in commutative harmonic analysis*, Providence, Rhode Island, 1997.
- R. Hamilton, Non-singular solutions of the Ricci flow on three-manifolds, *Comm. Anal. Geom.* 7 (1999), 695-729.